



**MEASUREMENT GUIDELINES  
FOR DVB SYSTEMS**

**DVB Document A014 Rev. 1  
March 1998**

***Reproduction of the document in whole or in part without prior permission of the DVB Project Office is  
forbidden.***

# Contents

1	Scope .....	10
2	References .....	10
3	Definitions and abbreviations .....	11
3.1	Definitions .....	11
3.2	Abbreviations .....	11
4	General .....	13
5	Measurement and analysis of the MPEG-2 Transport Stream .....	15
5.1	General .....	15
5.2	List of parameters recommended for evaluation .....	15
5.2.1	First priority: necessary for de-codability (basic monitoring) .....	16
5.2.2	Second priority: recommended for continuous or periodic monitoring .....	17
5.2.3	Third priority: application dependant monitoring .....	18
6	Common parameters for satellite and cable transmission media .....	22
6.1	System availability .....	22
6.2	Link availability .....	22
6.3	BER before RS decoder .....	23
6.3.1	Out of service .....	23
6.3.2	In service .....	23
6.4	Error events logging .....	23
6.5	Transmitter symbol clock jitter and accuracy .....	24
6.6	RF/IF signal power .....	24
6.7	Noise power .....	24
6.8	Bit error count after RS .....	25
6.9	IQ signal analysis .....	25
6.9.1	Introduction .....	25
6.9.2	Modulation Error Ratio (MER) .....	26
6.9.3	System Target Error (STE) .....	27
6.9.4	Carrier suppression .....	28
6.9.5	Amplitude Imbalance (AI) .....	28
6.9.6	Quadrature Error (QE) .....	29
6.9.7	Residual Target Error (RTE) .....	29
6.9.8	Coherent interferer .....	29
6.9.9	Phase Jitter (PJ) .....	30
6.9.10	Signal-to-Noise Ratio (SNR) .....	31
6.10	Interference .....	32
7	Cable specific measurements .....	33
7.1	Noise margin .....	33
7.2	Estimated noise margin .....	33
7.3	Signal quality margin test .....	33
7.4	Equivalent Noise Degradation (END) .....	34
7.5	BER vs. $E_b/N_0$ .....	36
7.6	Phase noise of RF carrier .....	36
7.7	Amplitude, phase and impulse response of the channel .....	36
7.8	Out of band emissions .....	37
8	Satellite specific measurements .....	38
8.1	BER before Viterbi decoding .....	38
8.2	Receive BER vs. $E_b/N_0$ .....	38
8.3	IF spectrum .....	39

9	Measurements specific for a terrestrial (DVB-T) system.....	40
9.1	RF accuracy (precision) .....	41
9.2	Selectivity .....	41
9.3	AFC capture range.....	41
9.4	Phase noise of Local Oscillators (LO).....	42
9.5	RF/IF signal power .....	43
9.6	Noise power .....	43
9.7	RF and IF spectrum .....	43
9.8	Receiver sensitivity/dynamic range for a Gaussian channel .....	43
9.9	Equivalent Noise Degradation (END) .....	44
9.10	Linearity characterization (shoulder attenuation).....	44
9.11	Power efficiency.....	44
9.12	Coherent interferer.....	44
9.13	BER vs. C/N ratio by variation of transmitter power.....	45
9.14	BER vs. C/N ratio by variation of Gaussian noise power .....	45
9.15	BER before Viterbi (inner) decoder.....	45
9.16	BER before RS (outer) decoder.....	45
	9.16.1 Out of Service .....	45
	9.16.2 In Service.....	45
9.17	BER after RS (outer) decoder .....	47
9.18	IQ signal analysis.....	47
	9.18.1 Introduction .....	47
	9.18.2 Modulation Error Ratio (MER) .....	48
	9.18.3 System Target Error (STE).....	48
	9.18.4 Carrier Suppression (CS).....	49
	9.18.5 Amplitude Imbalance (AI) .....	50
	9.18.6 Quadrature Error (QE).....	50
	9.18.7 Phase Jitter (PJ).....	51
9.19	Overall signal delay.....	52
9.20	SFN synchronization .....	53
9.21	Channel characteristics .....	53

Annex A: General measurement methods 54

A.1	Introduction.....	54
A.2	Null packet definition.....	54
A.3	Description of the procedure for "Estimated Noise Margin" by applying statistical analysis on the constellation data .....	55
A.4	Set-up for RF phase noise measurements using a spectrum analyser.....	56
A.5	Amplitude, phase and impulse response of the channel .....	58
A.6	Out of band emissions .....	58

Annex B: Examples for test set-up 59

B.1	System availability .....	59
B.2	Link availability .....	59
B.3	BER before RS .....	59
	B.3.1 Out of service measurement .....	59
	B.3.2 In service measurement.....	60
B.4	Event error logging .....	60
B.5	Transmitter symbol clock jitter and accuracy.....	60
B.6	RF/IF signal power.....	61

B.7	Noise power.....	61
B.7.1	Out of service measurement.....	61
B.7.2	In service measurement.....	62
B.8	BER after RS.....	62
B.9	I/Q signal analysis.....	62
B.10	Service data rate measurement.....	62
B.11	Noise margin.....	62
B.11.1	Recommended equipment.....	63
B.11.2	Remarks and precautions.....	63
B.11.3	Measurement procedure.....	64
B.12	Equivalent Noise Degradation (END).....	64
B.13	BER vs. $E_b/N_0$ .....	65
B.14	Equalizer specification.....	65
B.15	BER before Viterbi decoding.....	66
B.16	Receive BER vs. $E_b/N_0$ .....	67
B.17	IF spectrum.....	67
Annex C:	Measurement parameter definition.....	68
C.1	Definition of Vector Error Measures.....	68
C.2	Comparison between MER and EVM.....	68
C.3	Conclusions regarding MER and EVM.....	69
Annex D:	Exact values of BER vs. $E_b/N_0$ for DVB-C systems.....	70
Annex E:	Examples for the terrestrial system test set-up.....	71
E.1	RF accuracy.....	71
E.2	Selectivity.....	71
E.3	AFC capture range.....	72
E.4	Phase noise of Local Oscillators (LO).....	72
E.5	RF/IF signal power.....	73
E.5.1	Procedure 1 (power metre).....	73
E.5.2	Procedure 2 (spectrum analyser).....	73
E.6	Noise power.....	73
E.6.1	Procedure 1.....	74
E.6.2	Procedure 2.....	74
E.6.3	Procedure 3.....	74
E.6.4	Measurement of noise with a spectrum analyser.....	74
E.7	RF and IF spectrum.....	75
E.8	Receiver sensitivity/dynamic range for a Gaussian channel.....	75
E.9	Equivalent Noise Degradation (END).....	76

E.10	Linearity characterization (shoulder attenuation) .....	76
E.10.1	Equipment.....	76
E.10.2	Remarks and precautions.....	77
E.10.3	Measurement procedure (example for UHF channel 47) .....	77
E.11	Power efficiency .....	78
E.12	Coherent interferer.....	78
E.13	BER vs. C/N by variation of transmitter power .....	79
E.14	BER vs. C/N by variation of Gaussian noise power .....	79
E.15	BER before Viterbi (inner) decoder .....	79
Annex F:	Specification of test signals of DVB-T modulator.....	80
F.1	Introduction.....	80
F.2	Input signal .....	80
F.3	Test modes.....	81
F.4	Test points .....	81
F.5	File format for interchange of simulated data .....	81
F.5.1	Test point number .....	82
F.5.2	Length of data buffer.....	82
F.5.3	Bit ordering after inner interleaver .....	82
F.5.4	Carrier allocation.....	82
F.5.5	Scaling.....	83
F.5.6	Constellation .....	83
F.5.7	Hierarchy .....	83
F.5.8	Code rate LP and HP .....	83
F.5.9	Guard interval .....	84
F.5.10	Transmission mode.....	84
F.5.11	Data format.....	84
F.5.12	Example.....	84
Annex G:	Specification of test signals of DVB-T modulator.....	85
G.1	Overview .....	85
G.2	RF/IF power ("carrier") .....	85
G.3	Noise level.....	86
G.4	Energy-per-bit ( $E_b$ ) .....	86
G.5	C/N ratio and $E_b/N_0$ ratio.....	87
G.6	Practical application of the measurements.....	87
G.7	Example .....	88
G.8	Signal-to-Noise Ratio (SNR) and Modulation Error Ratio (MER).....	90
G.9	BER vs. C/N .....	90
G.10	Error probability of Quadrature Amplitude Modulation (QAM).....	91
G.11	Error probability of QPSK.....	92

G.12 Error probability after Viterbi decoding .....	93
G.13 Error probability after RS decoding .....	94
G.14 BEP vs. C/N for DVB cable transmission .....	94
G.15 BER vs. C/N for DVB satellite transmission .....	95
G.16 Adding noise to a noisy signal .....	96
Annex H: Bibliography	99

## **Digital Video Broadcasting (DVB) Project**

Founded in September 1993, the DVB Project is a market-led consortium of public and private sector organizations in the television industry. Its aim is to establish the framework for the introduction of MPEG-2 based digital television services. Now comprising over 200 organizations from more than 25 countries around the world, DVB fosters market-led systems, which meet the real needs, and economic circumstances, of the consumer electronics and the broadcast industry.

## 1 Scope

This BlueBook provides guidelines for measurement in Digital Video Broadcasting (DVB) satellite, cable and terrestrial and related digital television systems. The present document defines a number of measurement techniques, such that the results obtained are comparable when the measurement is carried out in compliance with the appropriate definition.

The present document uses terminology used in ETS 300 421 [5], ETS 300 429 [6], ETS 300 468 [7] and ETS 300 744 [9] and it should be read in conjunctions with them.

## 2 References

For the purposes of this BlueBook, the following references apply:

- [1] ISO/IEC 13818-1: "Information Technology - Generic coding of moving pictures and associated audio: Systems, Recommendation H.222.0".
- [2] ISO/IEC 13818-4: "Information Technology - Generic coding of moving pictures and associated audio: Compliance".
- [3] ISO/IEC 13818-9: "Information Technology - Generic coding of moving pictures and associated audio: Conformance".
- [4] ETR 154: "Digital Video Broadcasting (DVB); DVB implementation guidelines for the use of MPEG-2 Systems, Video and Audio in satellite, cable and terrestrial broadcasting applications".
- [5] ETS 300 421: "Digital Video Broadcasting (DVB); DVB framing structure, channel coding and modulation for 11/12 GHz satellite services".
- [6] ETS 300 429: "Digital Video Broadcasting (DVB); DVB framing structure, channel coding and modulation for cable systems".
- [7] ETS 300 468: "Digital Video Broadcasting (DVB); Specification for Service Information (SI) in DVB systems".
- [8] ETR 211: "Digital Video Broadcasting (DVB); DVB guidelines on implementation and usage of Service Information (SI)".
- [9] ETS 300 744: "Digital Video Broadcasting (DVB); Framing structure, channel coding and modulation for digital terrestrial television".
- [10] EN 50083-9: "Interfaces for CATV/SMATV Head-ends and similar Professional Equipment".
- [11] ITU-T Recommendation G.826: "Error performance and objectives for international, constant bitrate digital paths at or above the primary rate".
- [12] ITU-T Recommendation O.151: "Error performance measuring equipment operating at the primary rate and above".
- [13] ETS 300 473: "Digital Video Broadcasting (DVB); DVB Satellite Master Antenna Television (SMATV) distribution systems".
- [14] TS 301 191: "Digital Video Broadcasting (DVB); DVB mega-frame for Single Frequency Network (SFN) synchronization".
- [15] ETS 300 748: "Digital Video Broadcasting (DVB); Framing structure, channel coding and modulation for MVDS at 10 GHz and above".

[16] ETS 300 749: "Digital Video Broadcasting (DVB); Framing structure, channel coding and modulation for MMDS systems below 10 GHz".

### 3 Definitions and abbreviations

#### 3.1 Definitions

For the purposes of this BlueBook, the following definitions apply:

**MPEG-2:** Refers to the ISO/IEC 13818 series. Systems coding is defined in part 1. Video coding is defined in part 2. Audio coding is defined in part 3.

**multiplex:** A stream of all the digital data carrying one or more services within a single physical channel.

**Service Information (SI):** Digital data describing the delivery system, content and scheduling/timing of broadcast data streams etc. It includes MPEG-2 Program Specific Information (PSI) together with independently defined extensions.

**Transport Stream (TS):** A TS is a data structure defined in ISO/IEC 13818-1 [1]. It is the basis of the Digital Video Broadcasting (DVB) related standards.

#### 3.2 Abbreviations

For the purposes of this BlueBook, the following abbreviations apply:

AFC	Automatic Frequency Control
AI	Amplitude Imbalance
ASCII	American Standard Code for Information Interchange
ATM	Asynchronous Transfer Mode
AWGN	Additive White Gaussian Noise
BAT	Bouquet Association Table
BEP	Bit Error Probability
BER	Bit Error Rate
bslbf	bit string, left bit first
BW	BandWidth
C/N	ratio of RF or IF signal power to noise power
CA	Conditional Access
CATV	Community Antenna TeleVision
CPE	Common Phase Error
CRC	Cyclic Redundancy Check
CS	Carrier Suppression
CSO	Carrier Suppression O...
CTB	Carrier T... B...
CW	Continuous Wave
DC	Direct Current
DVB	Digital Video Broadcasting
DVB-C	Digital Video Broadcasting baseline system for digital cable television (ETS 300 429 [6])
DVB-CS	Digital Video Broadcasting baseline system for SMATV distribution systems (ETS 300 473 [13])
DVB-MC	Digital Video Broadcasting baseline system for Multi-point Video Distribution Systems below 10 GHz (ETS 300 749 [16])
DVB-MS	Digital Video Broadcasting baseline system for Multi-point Video Distribution Systems at 10 GHz and above (ETS 300 748 [15])
DVB-S	Digital Video Broadcasting baseline system for digital satellite television (ETS 300 421 [5])
DVB-T	Digital Video Broadcasting baseline system for digital terrestrial television (ETS 300 744 [9])
EB	Errored Block
EIT	Event Information Table
EMM	Entitlement Management Message
ENB	Equivalent Noise Bandwidth

END	Equivalent Noise Degradation
ES	Errored Second
ETR	ETSI Technical Report
ETS	European Telecommunication Standard
EVM	Error Vector Magnitude
FEC	Forward Error Correction
FFT	Fast Fourier Transform
HEX	Hexadecimal
ICI	Inter-Carrier Interference
IEC	International Electrotechnical Commission
IF	Intermediate Frequency
IFFT	Inverse FFT (Fast Fourier Transform)
IQ	In-phase/Quadrature components
IRD	Integrated Receiver Decoder
ISO	International Organization for Standardization
ITU	International Telecommunication Union
LAT	Link Available Time
LO	Local Oscillator
MER	Modulation Error Ratio
MIP	Mega-frame Initialization Packet
MMDS	Microwave Multi-point Distribution Systems (or Multi-channel Multi-point Distribution Systems)
MPEG	Moving Picture Experts Group
MVDS	Multi-point Video Distribution Systems
NIT	Network Information Table
OFDM	Orthogonal Frequency Division Multiplex
PAT	Program Association Table
PCR	Program Clock Reference
PE	Phase Error
PID	Packet Identifier
PJ	Phase Jitter
PLL	Phase Locked Loop
PMT	Program Map Table
PRBS	Pseudo Random Binary Sequence
printf	symbol in the C programming language
PSI	MPEG-2 Program Specific Information (as defined in ISO/IEC 13818-1 [1])
PTS	Presentation Time Stamps
QAM	Quadrature Amplitude Modulation
QE	Quadrature Error
QEF	Quasi Error Free
QEV	Quadrature Error Vector
QPSK	Quaternary Phase Shift Keying
RF	Radio Frequency
RMS	Root Mean Square
RS	Reed-Solomon
RST	Running Status Table (see ETS 300 468 [7])
RTE	Residual Target Error
SDP	Severely Disturbed Period
SDT	Service Description Table
SEP	Symbol Error Probability
SER	Symbol Error Rate
SES	Seriously Errored Second
SFN	Single Frequency Network
SI	Service Information
SMATV	Satellite Master Antenna TeleVision
SNR	Signal-to-Noise Ratio
STD	System Target Decoder
STE	System Target Error
STED	STE Deviation
STEM	STE Mean
TDT	Time and Date Table
TEV	Target Error Vector
TOT	Time Offset Table

TPS	Transmission Parameter Signalling
TS	Transport Stream
TV	TeleVision
UI	Unit Interval
uimsbf	unsigned integer, most significant bit first
UTC	Universal Time Co-ordinated

## 4 General

The Digital Video Broadcasting (DVB) set of digital TV standards specify baseline systems for various transmission media: satellite, cable, terrestrial, etc. Each baseline system standard defined the channel coding and modulation schemes for that transmission medium. The source coding was adapted from the MPEG-2 standard.

The design of these new systems has created a demand for a common understanding of measurement techniques and the interpretation of measurement results.

The present document is an attempt to give recommendations in this field by defining a number of measurement techniques in such detail that the results are actually comparable as long as the measurement is carried out in compliance with the given definition.

Engineers seeking to apply the methods described in the present document should be familiar with the standards for the respective baseline systems. Although most of the parameters specified in the present document are well known in communications, most of them should be interpreted with respect to the new environment, especially the transmission of digital TV signals or other related services.

The inclusion of each parameter in the present document is based on requirements from those who envisage having to work alongside the defined procedures. This includes network operators and providers of equipment for network installation, as well as manufacturers of Integrated Receiver Decoders (IRD) or test and measurement equipment.

The recommendations of the present document can be used:

- to set-up test beds or laboratory equipment for testing hardware for digital TV and other related services;
- to set these instruments to the appropriate parameters;
- to obtain unambiguous results that can be directly compared with results from other test set-ups;
- to form a potential basis for communicating results in an efficient way by using the definitions in the present document as references.

They are not intended to describe a set of compulsory tests.

The recommendations are grouped in several clauses. Since the MPEG-2 TS is the signal format used for the inputs and outputs of all baseline systems, clause 3 is devoted to the description of checking procedures for those parameters which are accessible in the TS packet header, i.e. without decoding scrambled or encrypted data. The aim of these tests is the provision of a simple and fast health check. It is meant neither as a MPEG-2 conformance test nor as a compliance test for all DVB related issues.

Clause 6 contains the parameters which are commonly addressed by various transmission media. For example, the measurement of the availability of transmission systems or links falls into this category, and it may be desirable to have the same definition for availability independent of the actual system in use.

Clauses 7 and 8 address the parameters which are specific for cable and satellite, DVB-C and DVB-S, they are also applicable to SMATV systems, DVB-CS, and possibly MMDS systems such as DVB-MC and DVB-MS.

Clause 9 addressed parameters specific to the terrestrial DVB environment (DVB-T).

Clauses 6, 7, 8, and 9 of the present document follow the same structure. For each parameter there is a description of the purpose of the recommended measurement procedure, the interface to which the

measurement instrument should be applied, and a description of the actual method of the measurement itself.

Apart from these clauses a number of annexes are included, containing recommendations for general aspects, examples of test set-ups and certain requirements for the test and measurement equipment.

If the interfaces for a described measurement procedure are to be found within the transmitter, the notation is provided in accordance with Figure 1 and Figure 12 for terrestrial. If the interfaces for the described measurement procedures are to be found within the receiver (test receiver or IRD), the notation is provided in accordance with Figure 2 and Figure 13 for terrestrial. These figures illustrate the general cases of a DVB transmitter and receiver, although certain functional blocks only appear in certain systems.

Most of the parameters can be measured with standard equipment such as spectrum analysers or constellation analysers. Other parameters are defined in a new way as a request to test and measurement equipment manufacturers to integrate this functionality in their products.

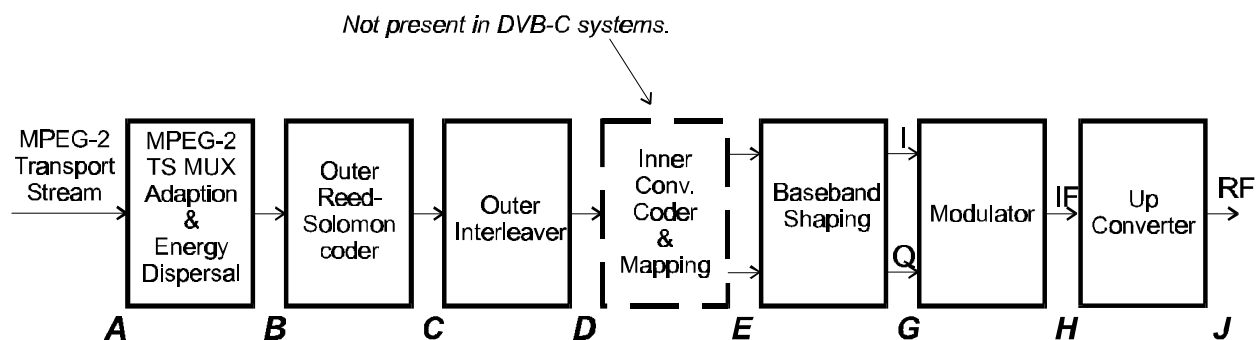

Figure 1: Transmitter block diagram

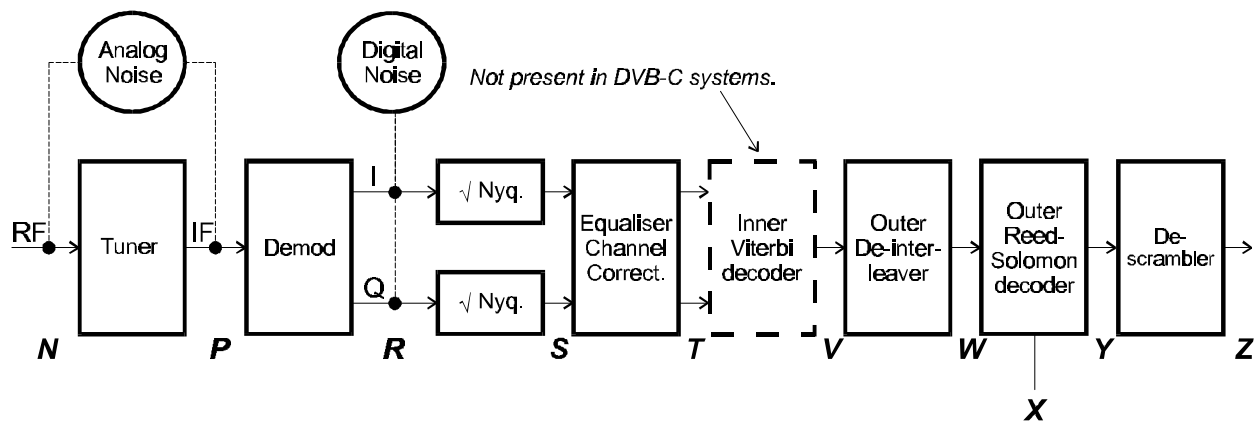

Figure 2: Receiver block diagram

## 5 Measurement and analysis of the MPEG-2 Transport Stream

### 5.1 General

The MPEG-2 Transport Stream (TS) is the specified input and output signal for all the baseline systems, i.e. for satellite, cable, SMATV, MMDS/MVDS and terrestrial distribution, which are defined in the DVB world so far. Therefore these interfaces are accessible in the transmission chain. Direct access is given on the transmitter side at the input of the respective baseline system. At other interfaces where the signal occurs in modulated form, access is possible by an appropriate demodulator that provides the TS interface as an output for further measurements.

The present document recommends a set of syntax and information consistency tests that can be applied to an MPEG-2 TS at the parallel interface, or either of the serial interfaces defined in EN 50083-9 [10].

The following assumptions and guiding principles were used in developing these tests:

- the tests are mainly intended for continuous or periodic monitoring of MPEG-2 TSs in an operational environment;
- the general aim of the tests is to provide a "health check" of the most important elements of the TS. The list of the tests is not exhaustive;
- the tests are consistent with the MPEG-2 Conformance tests defined in ISO/IEC 13818-4 [2], they do not replace them;
- the tests are consistent with the DVB-SI documents (ETS 300 468 [7], ETR 211 [8]), they do not replace them.

MPEG-2 and DVB-SI reserved values in the TS do not cause a test error indication.

In general the tests are performed on TS header information so that they are still valid when conditional access algorithms are applied, however a few of the tests may only be valid for an unscrambled or descrambled TS.

The tests are not dependant on any decoder implementation for consistency of results. The MPEG-2 T-STD model constraints, as defined in ISO/IEC 13818-1 (MPEG-2 Systems) [13], shall be satisfied as specified in ISO/IEC 13818-4 (MPEG-2 Conformance) [2].

Off-line tests are performed under stable conditions, no discontinuity or dynamic change can occur during an off-line test process.

The TS under test is assumed to be quasi error free.

Other digital performance parameters such as BER are not considered in this subclause.

### 5.2 List of parameters recommended for evaluation

This subclause tabulates the parameters which are recommended for continuous or periodic monitoring of the MPEG-2 TS.

The tests are grouped into three tables according to their importance for monitoring purposes.

The first table lists a basic set of parameters which are considered necessary to ensure that the TS can be decoded. The second table lists additional parameters which are recommended for continuous monitoring. The third table lists optional additional parameters which could be of interest for certain applications.

Any test equipment intended for the evaluation of these parameters should report test results by means of the indicators itemized in the second column of the tables under exactly the preconditions described in the third column of the tables.

If an indicator is set, then the TS is in error. However, since the indicators do not cover the entire range of possible errors, it cannot be concluded that there is no error if the indicator is not set.

If indicator 1.1 is activated then all other indicators are invalid. Each indicator is activated **only as long as** at least one of the described preconditions is fulfilled.

### 5.2.1 First priority: necessary for de-codability (basic monitoring)

No.	Indicator	Precondition	Reference
1.1	TS_sync_loss	Loss of synchronization with consideration of hysteresis parameters	ISO/IEC 13818-1 [1]: Subclause 2.4.3.3 and annex G.01
1.2	Sync_byte_error	Sync_byte not equal 0x47	ISO/IEC 13818-1 [1]: Subclause 2.4.3.3
1.3	PAT_error	PID 0x0000 does not occur at least every 0,5 seconds a PID 0x0000 does not contain a table_id 0x00 ( i.e. a PAT) Scrambling_control_field is not 00 for PID 0x0000	ISO/IEC 13818-1 [1]: Subclauses 2.4.4.3, 2.4.4.4
1.4	Continuity_count_error	Incorrect packet order a packet occurs more than twice lost packet	ISO/IEC 13818-1 [1]: Subclauses 2.4.3.2, 2.4.3.3
1.5	PMT_error	Sections with table_id 0x02, ( i. e. a PMT), do not occur at least every 0,5 seconds on the PID which is referred to in the PAT Scrambling_control_field is not 00 for all PIDs containing sections with table_id 0x02 (i.e. a PMT)	ISO/IEC 13818-1 [1]: Subclauses 2.4.4.3, 2.4.4.4, 2.4.4.8
1.6	PID_error	Referred PID does not occur for a user specified period	ISO/IEC 13818-1 [1]: Subclause 2.4.4.8

#### TS\_sync\_loss

The most important function for the evaluation of data from the MPEG-2 TS is the sync acquisition. The actual synchronization of the TS depends on the number of correct sync bytes necessary for the device to synchronize and on the number of distorted sync bytes which the device can not cope with.

It is proposed that five consecutive correct sync bytes (ISO/IEC 13818-1 [1], annex G.01) should be sufficient for sync acquisition, and two or more consecutive corrupted sync bytes should indicate sync loss.

**After synchronization has been achieved the evaluation of the other parameters can be carried out.**

#### Sync\_byte\_error

The indicator "Sync\_byte\_error" is set as soon as the correct sync byte (0x47) does not appear after 188 or 204 bytes. This is fundamental because this structure is used throughout the channel encoder and decoder chains for synchronization. It is also important that every sync byte is checked for correctness since the encoders may not necessarily check the sync byte. Apparently some encoders use the sync byte flag signal on the parallel interface to control randomizer re-seeding and byte inversion without checking that the corresponding byte is a valid sync byte.

#### PAT\_error

The Program Association Table (PAT), which only appears in PID 0x0000 packets, tells the decoder what programs are in the TS and points to the Program Map Tables (PMT) which in turn point to the component video, audio and data streams that make up the program (Figure 4).

If the PAT is missing then the decoder can do nothing, no program is decodable.

Nothing other than a PAT should be contained in a PID 0x0000.

### Continuity\_count\_error

For this indicator three checks are combined. The preconditions "Incorrect packet order" and "Lost packet" could cause problems for IRD which are not equipped with additional buffer storage and intelligence. It is not necessary for the test equipment to distinguish between these two preconditions as they are logically OR-ed, together with the third precondition, into one indicator.

The latter is also covering the packet loss that may occur on ATM links, where one lost ATM packet would cause the loss of a complete MPEG-2 packet.

The precondition "a packet occurs more than twice" may be symptomatic of a deeper problem that the service provider would like to keep under observation.

### PMT\_error

The Program Association Table (PAT) tells the decoder how many programs there are in the stream and points to the PMTs which contain the information where the parts for any given event can be found. Parts in this context are the video stream (normally one) and the audio streams and the data stream (e.g. Teletext). Without a PMT the corresponding program is not decodable.

### PID\_error

It is checked whether there exists a data stream for each PID that occurs. This error might occur where TS are multiplexed, or demultiplexed and again remultiplexed.

## 5.2.2 Second priority: recommended for continuous or periodic monitoring

No.	Indicator	Precondition	Reference
2.1	Transport_error	Transport_error_indicator in the TS-Header is set to "1"	ISO/IEC 13818-1 [1]: Subclauses 2.4.3.2, 2.4.3.3
2.2	CRC_error	CRC error occurred in CAT, PAT, PMT, NIT, EIT, BAT, SDT or TOT table	ISO/IEC 13818-1 [1]: Subclauses 2.4.4, annex B ETS 300 468 [7]: Subclause 5.2
2.3	PCR_error	PCR discontinuity of more than 100 ms occurring without specific indication. Time interval between two consecutive PCR values more than 40 ms	ISO/IEC 13818-1 [1]: Subclauses 2.4.3.4, 2.4.3.5 ISO/IEC 13818-4 [2]: Subclause 9.11.3 ETR 154 [4]: Subclause 4.5.4
2.4	PCR_accuracy_error	PCR accuracy of selected programme is not within $\pm 500$ ns	ISO/IEC 13818-1 [1]: Subclause 2.4.2.2
2.5	PTS_error	PTS repetition period more than 700 ms	ISO/IEC 13818-1 [1]: Subclauses 2.4.3.6, 2.4.3.7, 2.7.4
2.6	CAT_error	Packets with transport_scrambling_control not 00 present, but no section with table_id = 0x01 (i.e. a CAT) present Section with table_id other than 0x01 (i.e. not a CAT) found on PID 0x0001	ISO/IEC 13818-1 [1]: Subclause 2.4.4

### Transport\_error

The primary Transport\_error indicator is Boolean, but there should also be a resettable binary counter which counts the erroneous TS packets. This counter is intended for statistical evaluation of the errors. If an error occurs, no further error indication should be derived from the erroneous packet.

There may be value in providing a more detailed breakdown of the erroneous packets, for example, by providing a separate Transport\_error counter for each program stream or by including the PID of each erroneous packet in a log of Transport\_error events. Such extra analysis is regarded as optional and not part of this recommendation.

### CRC\_error

The CRC check for the CAT, PAT, PMT, NIT, EIT, BAT, SDT and TOT indicates whether the content of

the corresponding table is corrupted. In this case no further error indication should be derived from the content of the corresponding table.

#### PCR\_error

The PCRs are used to re-generate the local 27 MHz system clock. If the PCR do not arrive with sufficient regularity then this clock may jitter or drift. The receiver/decoder may even go out of lock. In DVB a repetition period of not more than 40 ms is recommended.

#### PCR\_accuracy\_error

The accuracy of  $\pm 500$  ns is intended to be sufficient for the colour subcarrier to be synthesized from system clock.

#### PTS\_error

The Presentation Time Stamps (PTS) should occur at least every 700 ms. They are only accessible if the TS is not scrambled.

#### CAT\_error

The CAT is the pointer to enable the IRD to find the EMMs associated with the CA system(s) that it uses. If the CAT is not present, the receiver is not able to receive management messages.

### 5.2.3 Third priority: application dependant monitoring

No.	Indicator	Precondition	Reference
3.1	NIT_error	Section with table_id other than 0x40 or 0x41 or 0x72 (i. e. not an NIT or ST) found on PID 0x0010 No section with table_id 0x40 or 0x41 (i.e. an NIT) in PID value 0x0010 for more than 10 seconds	ETS 300 468 [7]: Subclause 5.2.1 ETR 211 [8]: Subclauses 4.1, 4.4
3.2	SI_repetition_error	Repetition rate of SI tables outside of specified limits	ETS 300 468 [7]: Subclause 5.1.4 ETR 211 [8]: Subclause 4.4
3.3	Buffer_error	<b>TB_buffering_error</b> overflow of transport buffer ( $TB_n$ ) <b>TBsys_buffering_error</b> overflow of transport buffer for system information ( $Tb_{sys}$ ) <b>MB_buffering_error</b> overflow of multiplexing buffer ( $MB_n$ ) or if the <i>vbv_delay method</i> is used: underflow of multiplexing buffer ( $Mb_n$ ) <b>EB_buffering_error</b> overflow of elementary stream buffer ( $EB_n$ ) or if the <i>leak method</i> is used: underflow of elementary stream buffer ( $EB_n$ ) though <i>low_delay_flag</i> and <i>DSM_trick_mode_flag</i> are set to 0 else ( <i>vbv_delay method</i> ) underflow of elementary stream buffer ( $EB_n$ ) <b>B_buffering_error</b> overflow or underflow of main buffer ( $B_n$ ) <b>Bsys_buffering_error</b> overflow of PSI input buffer ( $B_{sys}$ )	ISO/IEC 13818-1 [1]: Subclause 2.4.2.3 ISO/IEC 13818-4 [2]: Subclauses 9.11.2, 9.1.4
(continued)			

**Table (concluded)**

<b>No.</b>	<b>Indicator</b>	<b>Precondition</b>	<b>Reference</b>
3.4	Unreferenced_PID	PID (other than PAT, CAT, CAT_PIDs, PMT_PIDs, NIT_PID, SDT_PID, TDT_PID, EIT_PID, RST_PID, reserved_for_future_use PIDs, or PIDs user defined as private data streams) not referred to by a PMT within 0,5 seconds (note)	ETS 300 468 [7]: Subclause 5.1.3
3.5	SDT_error	Sections with table_id = 0x42 (SDT, actual TS) not present on PID 0x0011 for more than 2 seconds Sections with table_ids other than 0x42, 0x46, 0x4A or 0x72 found on PID 0x0011	ETS 300 468 [7]: Subclause 5.1.3 ETR 211 [8]: Subclauses 4.1, 4.4
3.6	EIT_error	Sections with table_id = 0x4E (EIT-P/F, actual TS) not present on PID 0x0012 for more than 2 seconds Sections with table_ids other than in the range 0x4E - 0x6F or 0x72 found on PID 0x0012	ETS 300 468 [7]: Subclause 5.1.3 ETR 211 [8]: Subclauses 4.1, 4.4
3.7	RST_error	Sections with table_id other than 0x71 or 0x72 found on PID 0x0013	ETS 300 468 [7]: Subclause 5.1.3
3.8	TDT_error	Sections with table_id = 0x70 (TDT) not present on PID 0x0014 for more than 30 seconds Sections with table_id other than 0x70, 0x72 (ST) or 0x73 (TOT) found on PID 0x0014	ETS 300 468 [7]: Subclauses 5.1.3, 5.2.6 ETR 211 [8]: Subclauses 4.1, 4.4
3.9	Empty_buffer_error	Transport buffer (TB <sub>n</sub> ) not empty at least once per second or transport buffer for system information (TB <sub>sys</sub> ) not empty at least once per second or if the <i>leak method</i> is used multiplexing buffer (MB <sub>n</sub> ) not empty at least once per second.	ISO/IEC 13818-1 [1]: Subclauses 2.4.2.3, 2.4.2.6  ISO/IEC 13818-9 [3]: annex E  ISO/IEC 13818-4 [2]: Subclauses 9.1.1.2, 9.1.4
3.10	Data_delay_error	Delay of data (except still picture video data) through the TSTD buffers superior to 1 second or delay of still picture video data through the TSTD buffers superior to 60 seconds	ISO/IEC 13818-1 [1]: Subclauses 2.4.2.3, 2.4.2.6
NOTE: It is assumed that transition states are limited to 0,5 seconds, and these transitions should not cause error indications.			

**NIT\_error**

Network Information Tables (NITs) as defined by DVB contain information on frequency, code rates, modulation, polarization etc. of various programs which the decoder can use. It is checked whether NITs are present in the TS and whether they have the correct PID.

**SI\_repetition\_error**

For SI tables a maximum and minimum periodicity is specified in ETR 211 [8]. This is checked for this indicator.

**Buffer\_error**

For this indicator a number of buffers of the MPEG-2 reference decoder are checked whether they would have an underflow or an overflow.

**Unreferenced\_PID**

Each non-private program data stream should have its PID listed in the PMTs.

**SDT\_error**

The SDT describes the services available to the viewer. It is split into sub-tables containing details of the contents of the current TS (mandatory) and other TS (optional). Without the SDT, the IRD is unable to give the viewer a list of what services are available. It is also possible to transmit a BAT on the same PID, which groups services into "bouquets".

**EIT\_error**

The EIT describes what is on now and next on each service, and optionally details the complete programming schedule. The EIT is divided into several sub-tables, with only the "present and following" information for the current TS being mandatory. The EIT schedule information is only accessible if the TS is not scrambled.

**RST\_error**

The RST is a quick updating mechanism for the status information carried in the EIT.

**TDT\_error**

The TDT carries the current UTC time and date information. In addition to the TDT, a TOT can be transmitted which gives information about a local time offset in a given area.

As a further extension of the checks and measurements mentioned above an additional test concerning the SI is recommended: all mandatory descriptors in the SI tables should be present and the information in the tables should be consistent.

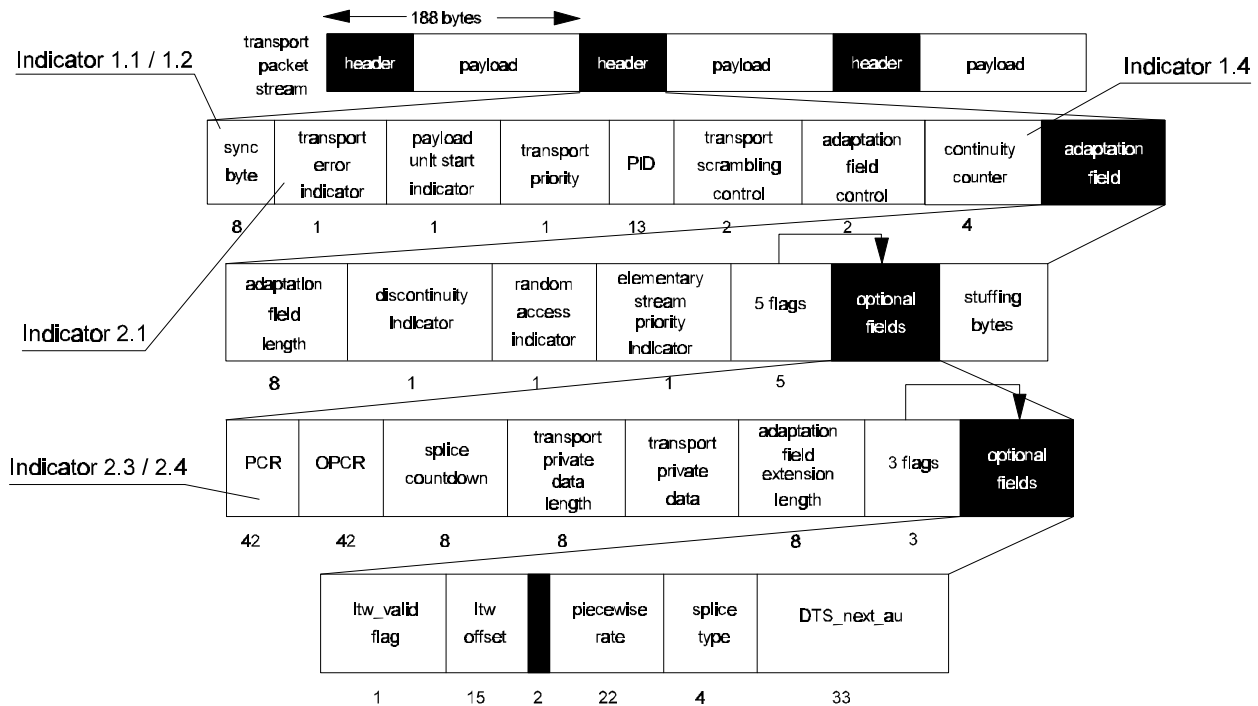

**Figure 3: Indicators related to TS syntax**

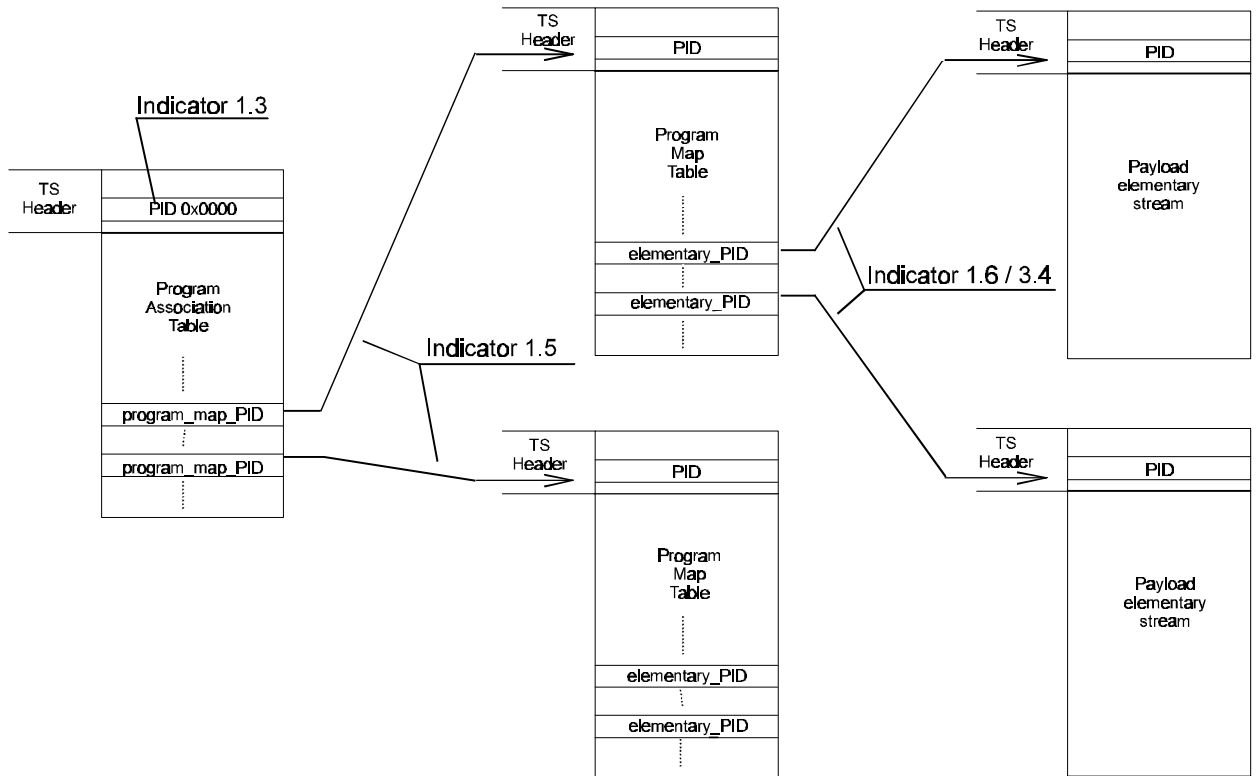

**Figure 4: Indicators related to TS structure**

## 6 Common parameters for satellite and cable transmission media

### 6.1 System availability

**Purpose:** The system availability describes the long term quality of the complete digital transmission system from MPEG-2 encoder to the measurement point.

**Interface** Z

**Method:** The definition of "System Availability" is based on the following list of performance parameters:

Errored Block (EB): An MPEG-2 TS packet with an uncorrectable error, which is indicated by the transport\_error\_indicator flag set.

Errored Second (ES): A one second period with one or more EBs.

Severely Disturbed Period (SDP): The duration of sync loss (as defined in clause 5 of the present document) or loss of signal.

Severely Errored Second (SES): A one second period which contains greater than a specified percentage of errored blocks, or at least one SDP. This percentage will not be specified in the present document, but should be the subject of agreements between the network operators and the program providers.

Based on these definitions, Unavailable Time in accordance with ITU-T Recommendation G.826 annex A.1 "Criteria for a Single Direction" [11] is defined as:

"A period of Unavailable Time begins at the onset of 10 consecutive SES events. These 10 seconds are considered to be part of the Unavailable Time. A period of Available Time begins at the onset of 10 consecutive non-SES events. These 10 seconds are considered to be part of Available Time".

The values in brackets could differ for different types of service (video, audio, data, etc.). An optional extension of this measurement is the ability to determine the availability for individual services.

### 6.2 Link availability

**Purpose** The link availability describes the long term quality of a specified link in a digital transmission chain. It could be used as a quality of service parameter in contracts between network operators and program providers.

**Interface** X (Overload indicator of the Reed-Solomon decoder).

**Method** The definition of Link availability is based on the following list of performance parameters:

Errored Block (EB): An MPEG-2 TS packet with an uncorrectable error, which is indicated by overload at the Reed-Solomon decoder.

Errored Second (ES): A one second period with one or more EB.

Severely Errored Second (SES): A one second period which contains greater than a specified percentage of errored blocks. This percentage will not be specified in the present document, but should be the subject of agreements between the network

operators and the program providers.

The loss of signal is not included in the link availability because the loss of signal may have occurred prior to the specified link.

Based on these definitions, Unavailable Time in accordance with ITU-T Recommendation G.826 annex A.1 [11] is defined as:

"A period of Unavailable Time begins at the onset of 10 consecutive SES events. These 10 seconds are considered to be part of the Unavailable Time. A period of Available Time begins at the onset of 10 consecutive non-SES events. These 10 seconds are considered to be part of Available Time".

The values in brackets could differ for different types of service (video, audio, data, etc.).

### 6.3 BER before RS decoder

**Purpose** The Bit Error Rate (BER) is the primary parameter which describes the quality of the digital transmission link.

**Interface** W

**Method** The BER is defined as the ratio between erroneous bits and the total number of transmitted bits.

Two alternative methods are available; one for "Out of Service" and a second for "In Service" use. In both cases, the measurement should only be done within the "link available time" as defined in subclause 6.2.

#### 6.3.1 Out of service

The basic principle of this measurement is to generate within the channel encoder a known, fixed, repeating sequence of bits, essentially of a pseudo random nature. In order to do this the data entering the sync-inversion/ randomization function is a continuous repetition of one fixed TS packet. This sequence is defined as the *null TS packet* in ISO/IEC 13818-1 [1] with all data bytes set to 0x00. i.e. the fixed packet is defined as the four byte sequence 0x47, 0x1F, 0xFF, 0x10, followed by 184 zero bytes (0x00). Ideally this would be available as an encoding system option (see clause A.2).

#### 6.3.2 In service

The basic assumption made in this measurement method is that the RS check bytes are computed for each link in the transmission chain. Under normal operational circumstances, the RS decoder will correct all errors and produce an error-free TS packet. If there are severe error-bursts, the RS decoding algorithm may be overloaded, and be unable to correct the packet. In this case the `transport_error_indicator` bit shall be set, no other bits in the packet shall be changed, and the 16 RS check bytes shall be recalculated accordingly before re-transmission on to another link. The BER measured at any point in the transmission chain is then the BER for that particular link only.

The number of erroneous bits within a TS packet will be estimated by comparing the bit pattern of this TS packet before and after RS decoding. If the measured value of BER exceeds  $10^{-3}$  then the measurement should be regarded as unreliable due to the limits of the RS decoding algorithm. Any TS packet that the RS decoder is unable to correct should cause the calculation to be restarted.

### 6.4 Error events logging

**Purpose** Error events logging creates a permanent error log which can subsequently be used to locate possible sources of errors. It may be used as a measure of "system availability" (see subclause 6.1 above).

**Interface** Z

**Method** Loss of sync, loss of signal, and reception of errored TS packets are logged.

In case of sync or signal loss, the absolute time of loss shall be recorded, along with either the duration of loss or the time of recovery from loss. A default time resolution of 1 second is strongly recommended for this measurement, but other time intervals may be appropriate depending on the application.

In case of reception of EBs (see subclause 6.1), the number of such events in each second shall be logged, together with the PID and the total number of received packets of this PID within the resolution time. Logging of any other parameters (e.g. overloading of Reed-Solomon decoder, original\_network\_id, service\_id) are optional.

The error log shall store the most recent 1 000 error events as a minimum. Provision should be made to access all of the error information in a form suitable for further data processing.

## 6.5 Transmitter symbol clock jitter and accuracy

**Purpose** Inaccuracies of the symbol clock concerning absolute frequency, frequency drift and jitter may introduce intersymbol interference. Additionally, the accuracy of transmitted clock references like the Program Clock Reference (PCR) can be influenced. Therefore the degradation of signal quality due to symbol clock inaccuracies has to be negligible. Symbol clock jitter and accuracy can be degraded if the symbol clock is directly synthesized from an unstable TS data clock. For this reason, the measurement should be performed while the transmitter is driven by a TS to ensure a worst case measurement is obtained.

**Interface** E

**Method** For measurements the absolute frequency, frequency wander and timing jitter are of interest. A Phase Locked Loop (PLL) circuit can be used for synchronization to the symbol clock and according to the loop bandwidth, timing jitter is suppressed and low frequency drift (wander) is still present at the output of the loop oscillator. Jitter can be measured with an oscilloscope by triggering with the extracted clock. Jitter is usually expressed as a peak-to-peak value in UI (Unit Interval) where one UI is equal to one clock cycle ( $T_{\text{symbol}}$ ). For measurements of the absolute frequency and frequency wander the output of the clock extractor can be used or the symbol clock directly using an appropriate frequency counter.

## 6.6 RF/IF signal power

**Purpose** Level measurement is needed to set up a network.

**Interface** Any RF/IF interface, N, P.

**Method** The signal power, or wanted power, is defined as the mean power of the selected signal as would be measured with a thermal power sensor. Care should be taken to limit the measurement to the bandwidth of the wanted signal. When using a spectrum analyser or a calibrated receiver, it should integrate the signal power within the nominal bandwidth of the signal (symbol rate  $\times (1 + \alpha)$ ).

## 6.7 Noise power

**Purpose** Noise is a significant impairment in a transmission network.

**Interface** N (out of service) or T (in service)

**Method** The noise power (mean power), or unwanted power, is measured with a spectrum analyser (out of service) or an estimate is obtained from the IQ diagram (in service), see subclause 6.9.9. The noise level is specified using either the occupied bandwidth of the

signal, which is equal to the symbol rate  $\times (1 + \alpha)$ . See annex G.

## 6.8 Bit error count after RS

**Purpose** To measure whether the MPEG-2 TS is quasi error free.

**Interface** Z

**Method** The same principle as used for the "Out of service measurement" of the "BER before the Reed-Solomon decoder" described in subclause 6.3.2, with the modification that the result is presented as an error count rather than a ratio. The receiver only has to compare the received TS packets with the Null packets as defined in clause A.2.

## 6.9 IQ signal analysis

### 6.9.1 Introduction

Assuming:

- a constellation diagram of M symbol points; and
- a measurement sample of N data points, where N is sufficiently larger than M to deliver the wanted measurement accuracy; and
- the co-ordinates of each received data point j being  $I_j + \delta I_j$ ,  $Q_j + \delta Q_j$  where I and Q are the co-ordinates of the ideal symbol point and  $\delta I$  and  $\delta Q$  are the offsets forming the error vector of the data point (see clause A.3).

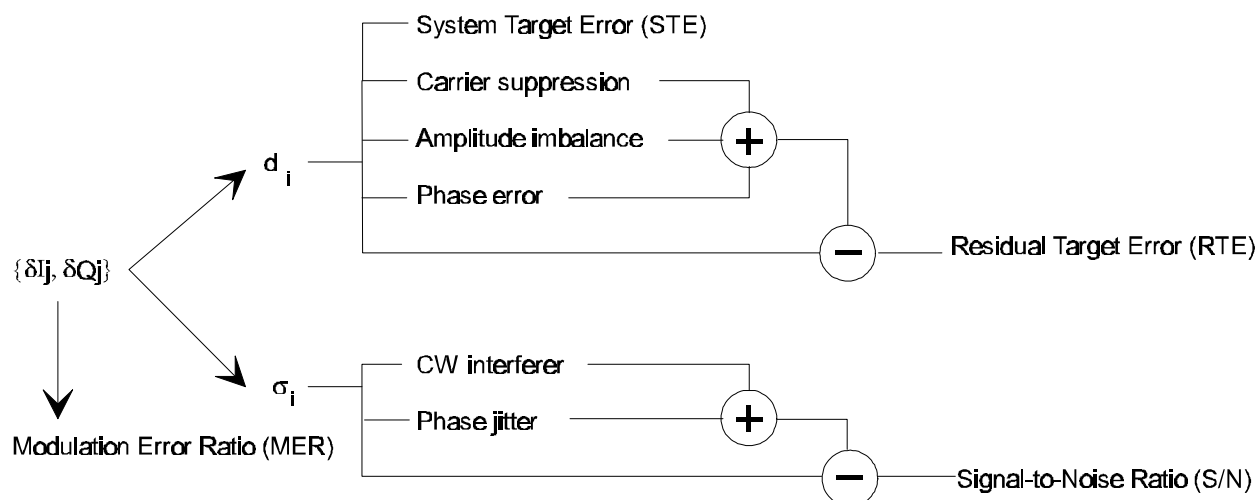

**Figure 5: Relationship between the parameters describing different IQ distortions**

Modulation Error Ratio (MER) and the related Error Vector Magnitude (EVM) are calculated from all N data points without special pre-calculation for the data belonging to the M symbol points.

With the aim of separating individual influences from the received data, for each point i of the M symbol points the mean distance  $d_i$  and the distribution  $\sigma_i$  can be calculated from those  $\delta I_j$ ,  $\delta Q_j$  belonging to the point i.

From the M values  $\{d_1, d_2, \dots, d_M\}$  the influences/parameters:

- Origin offset;
- Amplitude Imbalance (AI); and
- Quadrature Error (QE);

can be extracted and removed from the  $d_i$  values, allowing to calculate the Residual Target Error (RTE) with the same algorithm as the System Target Error (STE) from  $\{d_1, d_2, \dots, d_M\}$ .

From the statistical distribution of the M clouds (denoted by  $\sigma_i$  in Figure 5) parameters:

- phase jitter; and
- CW interferer,

may be extracted. The remaining clouds (after elimination of the above two influences) are assumed to be due to Gaussian noise only and are the basis for calculation of the signal-to-noise ratio. The parameter may include - besides noise - also some other disturbing effects, like small non-coherent interferers or residual errors from the equalizer. From the SNR value the Carrier/Noise value can be estimated (see clause A.3).

When using the interfaces E or G filtering of the signal before the interface should be considered.

### 6.9.2 Modulation Error Ratio (MER)

**Purpose** To provide a single "figure of merit" analysis of the received signal.

This figure is computed to include the total signal degradation likely to be present at the input of a commercial receiver's decision circuits and so give an indication of the ability of that receiver to correctly decode the signal.

**Interface** E, G, S, T

**Method** The carrier frequency and symbol timing are recovered, which removes frequency error and phase rotation. Origin offset (e.g. cause by residual carrier or DC offset), quadrature error and amplitude imbalance are not corrected.

A time record of N received symbol co-ordinate pairs  $(\tilde{I}_j, \tilde{Q}_j)$  is captured.

For each received symbol, a decision is made as to which symbol was transmitted. The ideal position of the chosen symbol (the centre of the decision box) is represented by the vector  $(I_j, Q_j)$ . The error vector  $(\delta I_j, \delta Q_j)$  is defined as the distance from this ideal position to the actual position of the received symbol.

In other words, the received vector  $(\tilde{I}_j, \tilde{Q}_j)$  is the sum of the ideal vector  $(I_j, Q_j)$  and the error vector  $(\delta I_j, \delta Q_j)$ .

The sum of the squares of the magnitudes of the ideal symbol vectors is divided by the sum of the squares of the magnitudes of the symbol error vectors. The result, expressed as a power ratio in dB, is defined as the Modulation Error Ratio (MER).

$$MER = 10 \times \log_{10} \left\{ \frac{\sum_{j=1}^N (I_j^2 + Q_j^2)}{\sum_{j=1}^N (\delta I_j^2 + \delta Q_j^2)} \right\} dB$$

The definition of MER does not assume the use of an equalizer, however the measuring receiver may include a commercial quality equalizer to give more representative results when the signal at the measurement point has linear impairments.

When an MER figure is quoted it should be stated whether an equalizer has been used.

It should be reconsider that MER is just one way of computing a "figure of merit" for a vector modulated signal. Another "figure of merit" calculation is Error Vector Magnitude (EVM) defined in clause A.3. It is also shown in clause A.3 that MER and EVM are closely

related and that one can generally be computed from the other.

MER is the preferred first choice for various reasons itemized in clause A.3.

### 6.9.3 System Target Error (STE)

**Purpose** The displacement of the centres of the clouds in a constellation diagram from their ideal symbol point reduces the noise immunity of the system and indicates the presence of special kind of distortions like Carrier Suppression, Amplitude Imbalance, Quadrature Error (QE) and e.g. non-linear distortions. STE gives a global indication about the overall distortion present on the raw data received by the system.

**Interface** E, G, S, T

**Method** For each of the M symbol points in a constellation diagram compute the distance  $d_i$  between the theoretical symbol point and the point corresponding to the mean of the cloud of this particular symbol point. This quantity ( $\bar{d}_i$ ) is called Target Error Vector (TEV) and is shown in Figure 6.

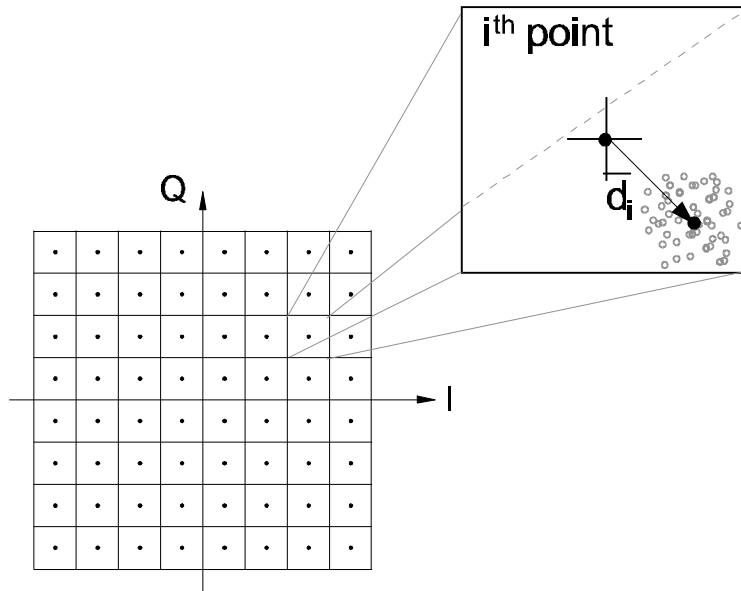

**Figure 6: Definition of Target Error Vector (TEV)**

From the magnitude of the M Target Error Vectors calculate the mean value and the standard deviation (normalized to  $S_{rms}$ , defined as the RMS amplitude value of the points in the constellation), obtaining the System Target Error Mean (STEM) and the System Target Error Deviation (STED) as follows:

$$S_{rms} = \sqrt{\frac{1}{N} \sum_{j=1}^N (I_j^2 + Q_j^2)}$$

$$STEM = \frac{1}{M \times S_{rms}} \sum_{i=1}^M |\bar{d}_i|$$

$$STED = \sqrt{\frac{\sum_{i=1}^M |\bar{d}_i|^2}{M \times S_{rms}^2} - STEM^2}$$

#### 6.9.4 Carrier suppression

**Purpose** A residual carrier is an unwanted coherent CW signal added to the QAM signal. It may have been produced by DC offset voltages of the modulating I and/or Q signal or by crosstalk from the modulating carrier within the modulator.

**Interface** E, G, S, T

**Method** Search for systematic deviations of all constellation points and isolate the residual carrier. Calculate the Carrier Suppression (CS) from the formula:

$$CS = 10 \times \log_{10} \left( \frac{P_{sig}}{P_{RC}} \right)$$

where  $P_{RC}$  is the power of the residual carrier and  $P_{sig}$  is the power of the QAM signal (without residual carrier).

#### 6.9.5 Amplitude Imbalance (AI)

**Purpose** To separate the QAM distortions resulting from AI of the I and Q signal from all other kind of distortions.

**Interface** E, G, S, T

**Method** Calculate the I and Q gain values  $v_I$  and  $v_Q$  from all points in a constellation diagram eliminating all other influences. Calculate AI from  $v_I$  and  $v_Q$ :

$$AI = \left( \frac{v_2}{v_1} - 1 \right) \times 100 \%$$

$$\text{with } v_1 = \min(v_I, v_Q) \quad \text{and} \quad v_2 = \max(v_I, v_Q) \quad .$$

$$v_I = \frac{1}{M} \sum_{i=1}^M \frac{I_i + (\bar{d}_i)_I}{I_i}$$

$$(\bar{d}_i)_I = \frac{1}{N} \sum_{j=1}^N \delta I_j \quad (\text{I - component of } d_i \text{ as given in subclause 4.9.3 System Target Error})$$

$$v_Q = \frac{1}{M} \sum_{i=1}^M \frac{Q_i + (\bar{d}_i)_Q}{Q_i}$$

$$(\bar{d}_i)_Q = \frac{1}{N} \sum_{j=1}^N \delta Q_j \quad (\text{Q - component of } d_i \text{ as given in subclause 4.9.3 System Target Error})$$

$$(\bar{d}_i)_I + (\bar{d}_i)_Q = \bar{d}_i$$

### 6.9.6 Quadrature Error (QE)

**Purpose** The phases of the two carriers feeding the I and Q modulators have to be orthogonal. If their phase difference is not  $90^\circ$  a typical distortion of the constellation diagram results. The receiver usually aligns its reference phase in such a way that the  $90^\circ$  error ( $\Delta\phi$ ) is equally spread between  $\phi_1$  and  $\phi_2$ .

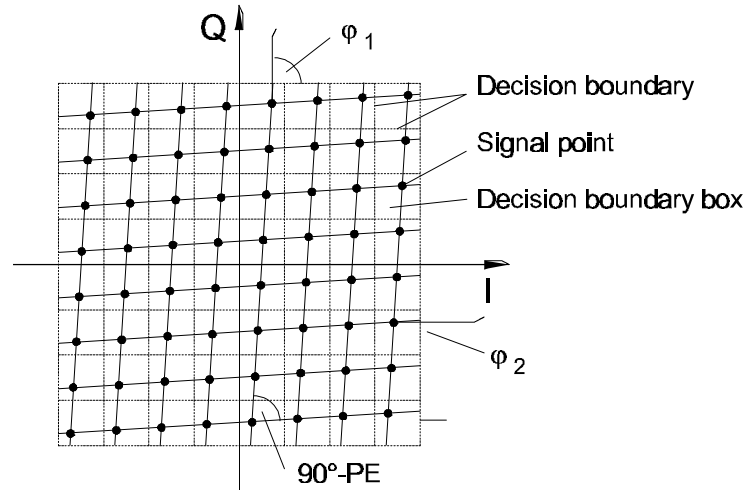

**Figure 7: Distortion of constellation diagram resulting from I/Q Quadrature Error (QE)**

**Interface** E, G, S, T

**Method** Search for the constellation diagram error shown in Figure 7 and calculate the absolute value of the phase difference  $\Delta\phi = |\phi_1 - \phi_2|$  after having eliminated all other influences and convert this into degrees.

$$QE = \frac{180^\circ}{\pi} \sum |\phi_1 - \phi_2|$$

### 6.9.7 Residual Target Error (RTE)

**Purpose** The RTE is a subset of the distortions measured as System Target Error (STE) with influences of Carrier Suppression, Amplitude Imbalance, and Quadrature Error (QE) removed. The remaining distortions may result mainly from non-linear distortions.

**Interface** E, G, S, T

**Method** Remove from the Target Error Vectors  $d_i$ , which have been used to calculate the Symbol Target Error (STE), the influences of Carrier Suppression, Amplitude Imbalance, and Quadrature Error (QE), call the remaining vectors  $d'_i$  and calculate the mean value of their magnitudes.

$$RTE = \frac{1}{M \times S_{rms}} \sum_{i=1}^M |d'_i|$$

### 6.9.8 Coherent interferer

**Purpose** Coherent interferers (not necessarily related to the main carrier) are usually measured with a spectrum analyser (out of service, and in some cases in service with narrow resolution bandwidth filter and video filter at interfaces N and P) or either of the following methods

described below (in service). In a constellation diagram a sine-wave interferer will change the noisy clouds of each system point into a "donut" shape. From the statistical distribution of the clouds, the amplitude of the interferer can be calculated if it is above a certain limit. If the frequency of the interferer is of interest or more than one interferer is present, the Fourier transform method should be used.

**Interface** E, G, S, T

**Method** Perform a Fourier transform of a time record of error vectors to produce a frequency spectrum of the interferers.

Alternatively, calculate the RMS magnitude  $a_i$  of the coherent interferer preferably from the statistical distribution of the 4 inner clouds computed from the measurement sample. Normalize  $a_i$  to  $S_{rms}$  and express the result in dB.

$$C/I = 20 \times \log_{10} \frac{S_{rms}}{a_i} \text{ [dB]}$$

NOTE 1: In the present document, the term "coherent" is applied to signals that have a high degree of correlation with a time shifted version of itself.

EXAMPLE 1: Continuous Waves (CW) or even single channel analogue video modulated carriers, these signals are coherent although they do not need to be related to the carrier of the digital channel under test.

NOTE 2: Non-coherent is applied to signals with very low correlation to a time shifted version of themselves.

EXAMPLE 2: Random noise or digitally modulated carriers, as well as the combined result of inter-modulation by many carriers.

### 6.9.9 Phase Jitter (PJ)

**Purpose** The PJ of an oscillator is due to fluctuations of its phase or frequency. Using such an oscillator to modulate a digital signal results in a sampling uncertainty in the receiver, because the carrier regeneration cannot follow the phase fluctuations.

The signal points are arranged along a curved line crossing the centre of each decision boundary box as shown in Figure 8 the four "corner decision boundary boxes".

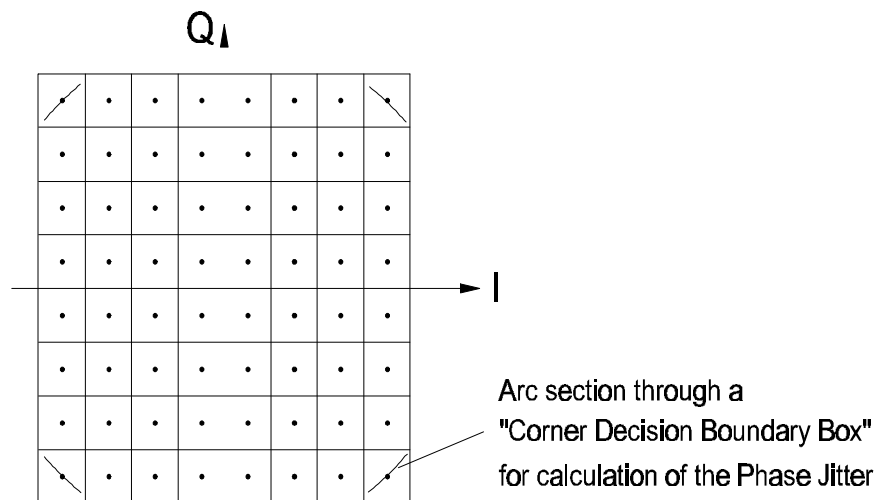

**Figure 8: Position of arc section in the constellation diagram to define the PJ (example: 64-QAM)**

**Interface** E, G, S, T

**Method** Phase Jitter (PJ) can be calculated theoretically using the following algorithm:

For every received symbol:

1) Calculate the angle between the I-axis of the constellation and the vector to the received symbol  $(\tilde{I}, \tilde{Q})$ :

$$\phi_1 = \arctan \frac{\tilde{Q}}{\tilde{I}}$$

2) Calculate the angle between the I-axis of the constellation and the vector to the corresponding ideal symbol  $(I, Q)$ :

$$\phi_2 = \arctan \frac{Q}{I}$$

3) Calculate the error angle:

$$\phi_E = \phi_1 - \phi_2$$

From these N error angles calculate the RMS phase jitter:

$$PJ = \sqrt{\frac{1}{N} \sum_{i=1}^N \phi_{E_i}^2 - \frac{1}{N^2} \left( \sum_{i=1}^N \phi_{E_i} \right)^2}$$

However, the following method may be more practical.

The first approximation of the "arc section" of a "corner decision boundary box" is a straight line parallel to the diagonal of the "decision boundary box". Additionally the curvature of the Phase Jitter (PJ) trace has to be taken into account when calculating the standard deviation of the PJ. The mean value of the PJ is calculated in degrees.

$$PJ = \frac{180^\circ}{\pi} \times \arcsin \left( \frac{\sigma_{PJ}}{\sqrt{2} \times (\sqrt{M} - 1) \times d} \right)$$

where M = order of QAM and 2d = distance between two successive boundary lines.

Within the argument of the arc sine function, the standard deviation of the PJ is referenced to the distance from the centre of the "corner decision boundary box" to the centre point of the QAM signal.

### 6.9.10 Signal-to-Noise Ratio (SNR)

**Purpose** *To be defined.*

**Interface** *To be defined.*

**Method** *To be defined.*

## 6.10 Interference

**Purpose** In a CATV network interference products can be caused by modulators and frequency converters.

**Interface** N (out of service) or S, T (in service)

**Method** Out of service interference products are measured with a spectrum analyser and in some cases in-service measurements can be done if a narrow resolution bandwidth filter and video filtering is used to lower the response of the instrument to the signal spectrum. If the frequency of the expected interference is known, the measurement can be made easily and quickly. In-service information of coherent interference can be derived from the constellation, subclause 6.9.8.

In some circumstances the residual carrier level can be measured with a spectrum analyser, by using a narrow resolution bandwidth filter and video filtering, at the interfaces H, J, N, P. The CS can be calculated as ten times the logarithm (base 10) of the ratio of the signal power measured as described in subclause 6.6, to the measured remaining carrier power.

## 7 Cable specific measurements

In SMATV networks that distribute the 1st satellite IF directly to subscribers, some parameters of this clause can be defined accordingly for QPSK modulated signals.

### 7.1 Noise margin

**Purpose** To provide an indication of the reliability of the transmission channel. The noise margin measurement is a more useful measure of system operating margin than a direct BER measurement due to the steepness of the BER curve.

**Interface** The reference interface for the noise injection is the RF interface (N). For practical implementation, other interfaces can be used, provided equivalence can be shown, for example P.

**Method** The noise margin is computed by adding white Gaussian noise on the received signal. The noise margin will be the difference in dB between the carrier to noise ratio (C/N) of the received signal and the carrier to noise ratio for a BER of  $10^{-4}$  (before RS decoding).

### 7.2 Estimated noise margin

**Purpose** To provide an indication of the reliability of the transmission channel without switching off the service. The noise margin measurement is a more useful measure of system operating margin than a direct BER measurement due to the steepness of the BER curve.

**Interface** T

**Method** The estimated noise margin is computed by simulating the addition of white Gaussian noise to the demodulated data and predicting the resulting BER by statistical methods.

The noise margin will be the difference in dB between the estimated SNR of the received signal and the synthesized SNR which gives a predicted BER of  $10^{-4}$  (before RS decoding).

### 7.3 Signal quality margin test

**Purpose** A fast and simple pass/fail measurement that can provide an indication of the quality of the digital service at various nodes in the cable distribution network.

This measurement will provide a first indication of the margin to failure of the digital service. It can be used as a signal quality check during installation, and as a maintenance tool for basic monitoring of signal quality through the network.

**Interface** T. The measurement assumes the use of an equalizer.

**Method** The demodulated, equalized and sampled IQ constellation characteristically has data points clustered around each of the ideal data point locations. For a high quality signal, most of the received data points are close to the ideal location and the clusters' spread is small relative to the overall constellation size. As the signal is degraded by noise and other impairments the clusters' spreading increases leading to a corresponding increase in symbol errors as more data points stray over the inter-symbol decision boundaries. In general, the amount of spread in the received data points is an indication of the signal quality.

To measure the amount of data point spreading in the received constellation we place decision boundaries to the left, right, above and below each constellation point. These boundaries form a "quality threshold" box around each constellation point. The edges of this box are closer to the ideal data point than the inter-symbol decision boundaries so a significant proportion of the received data points may lie outside the quality threshold box even under normal conditions.

At all constellation points, the number of data points falling inside and outside the quality threshold box are counted in order to compute a percentage which is then used to trigger

the pass/fail indication.

Since the acceptable spread will vary depending on the point of measurement within the network, the size of the quality threshold box is user selectable from a small range of sizes. For example, a small quality threshold box for measurements at the head-end, a larger quality threshold box for measurements at the customers premises.

The individual quality threshold box sizes are chosen by the network operator to give the same pass/fail threshold at each measurement point in the network taking into account the signal degradation expected under normal operating conditions.

The choice of threshold percentage and likely quality threshold box, the relationship between signal quality margin and the critical BER of  $10^{-4}$ , the definition of an appropriate equalizer (see clause A.3), and the possibility to include linear distortions in this measurement are all subject to further study.

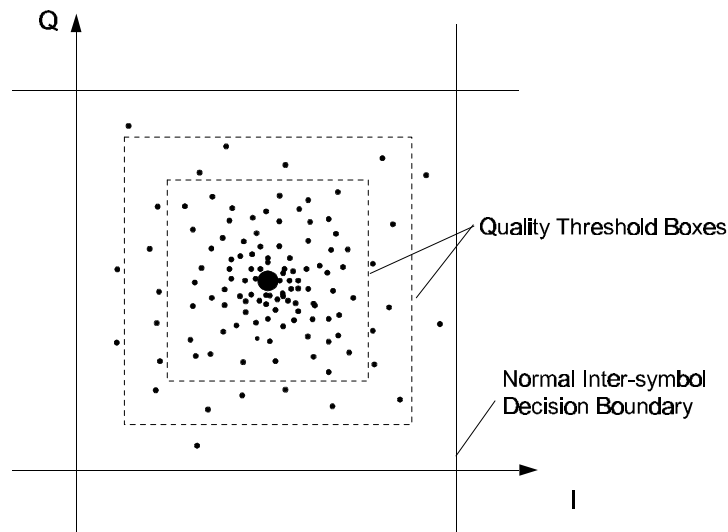
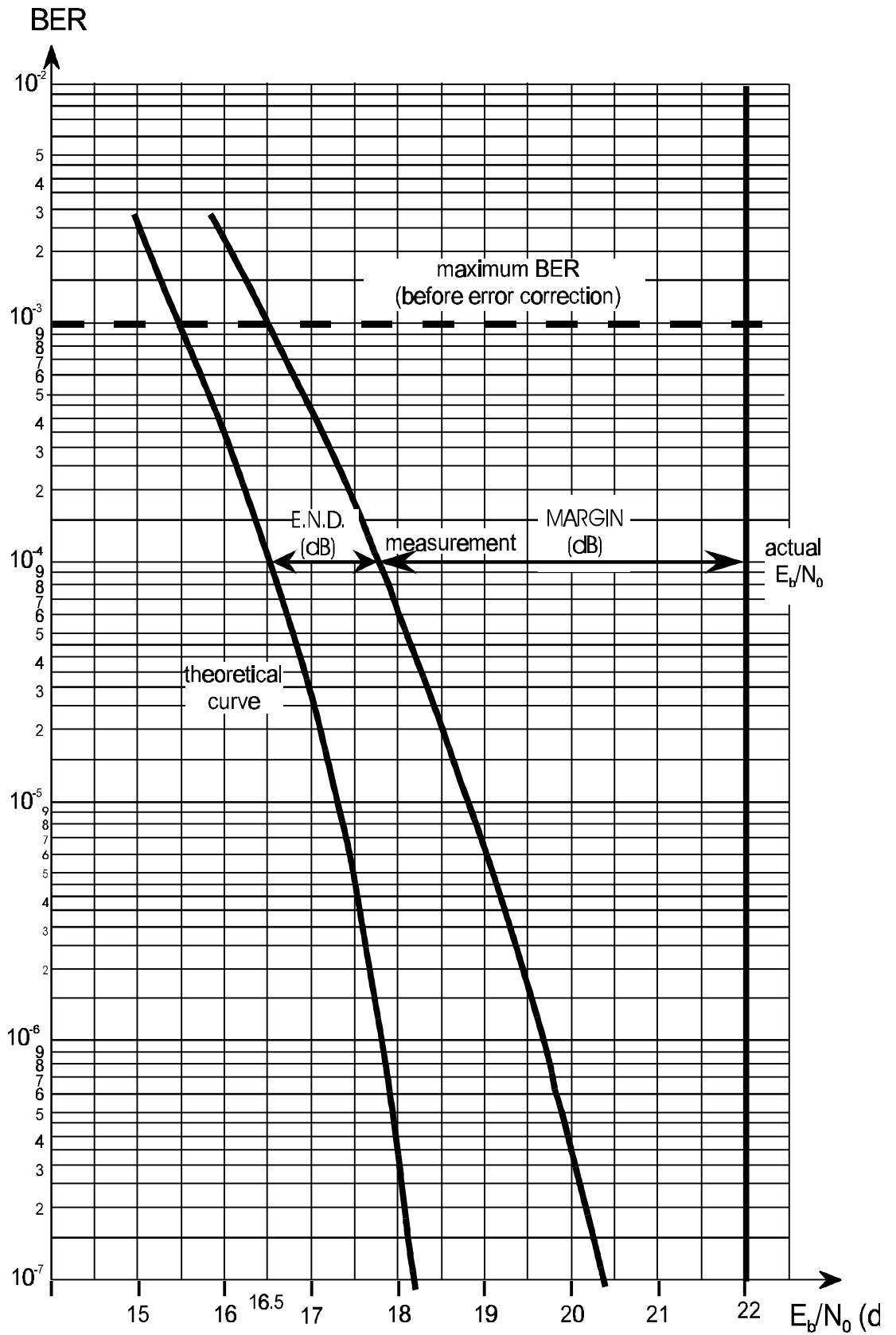

**Figure 9: Quality thresholds for single constellation in the I/Q plane**

A single constellation point in the I/Q plane is shown in Figure 9. Different quality thresholds can be defined within the normal decision boundaries.

#### **7.4 Equivalent Noise Degradation (END)**

- Purpose** END is a measure of the implementation loss caused by the network or the equipment where the reference is the ideal performance.
- Interface** T (BER) and N or P or R (noise injection)
- Method** The END is obtained from the difference in dB of the C/N or  $E_b/N_0$  ratio needed to reach a BER of  $10^{-4}$  and the C/N or  $E_b/N_0$  ratio that would theoretically give a BER of  $10^{-4}$ , for a Gaussian channel.



**Figure 10: Measurement of equivalent noise degradation**

Figure 10 is not the true theoretical curve representing BER in DVB-C systems, but only an example. This figure will be updated by true theoretical values and, if necessary, tables corresponding to these values will be given in an annex to the present document, when available. The theoretical curve in this figure needs to be updated from data in the table contained in annex D.

## 7.5 BER vs. $E_b/N_0$

**Purpose** The BER vs.  $E_b/N_0$  measurement enables a graph to be drawn which shows the implementation loss of the system over a range of Bit Error Rates. The residual BER at high  $E_b/N_0$  values is an indicator of possible network problems. C/N measurements can be converted to  $E_b/N_0$  as shown

$$\frac{E_b}{N_0} = \frac{C}{N} + 10 \log_{10} \frac{BW_{noise}}{f_s \times m} \quad [\text{in dB}]$$

$m$  is the number of bits per symbol ( $m = 6$  for 64-QAM) and  $N$  is measured in the Nyquist bandwidth (symbol rate as indicated in subclause 6.7).

**Interface** T (BER) and N or P or R (noise injection)

**Method** The BER vs.  $E_b/N_0$  curve will be measured using the RF and noise power measurements described above. The BER range of interest is  $10^{-7}$  to  $10^{-3}$ . The  $E_b/N_0$  value is based on the gross bitrate (including RS error correction) and the net bitrate value of  $E_b/N_0$  can easily be calculated using the RS rate, using the following conversion factor for a RS (204, 188) code (see annex G).

$$10 \times \log_{10} \left( \frac{204}{188} \right) = +0,35 \text{ dB}$$

## 7.6 Phase noise of RF carrier

**Purpose** Phase noise can be introduced at the transmitter side or by the receiver due to unstable local oscillators.

Phase noise outside the loop bandwidth of the carrier recovery circuit leads to a circular smearing of the constellation points in the I/Q plane. This reduces the operating margin (noise margin) of the system and may directly increase the BER.

**Interface** Any RF/IF interface, N, P

**Method** Phase noise power density is normally expressed in dBc/Hz at a certain frequency offset from the carrier. Out of service phase noise will be measured with a spectrum- or modulation- analyser.

## 7.7 Amplitude, phase and impulse response of the channel

**Purpose** Linear distortions, like amplitude and phase response errors and echoes, will be caused for instance by long lengths of cable and the cascading of a high number of amplifiers. The impulse response is important to localize the discrete reflections that may occur in cable networks.

**Interface** S, T

**Method** The impulse response of the transmission channel can be calculated (inverse Fourier transform) from the amplitude and phase response. The amplitude and phase response are defined as the RF-channel response. The amplitude response of the transmission channel can be derived from the equalizer tap coefficients or can be calculated directly from the "I" and "Q" samples, for example by using auto- and cross-correlation functions.

## **7.8 Out of band emissions**

<b>Purpose</b>	To prevent interference in other channels in the network the RF signal shall comply with the spectrum mask specified for the network under test.
<b>Interface</b>	Transmitter output, J
<b>Method</b>	Spectrum analyser

## 8 Satellite specific measurements

### 8.1 BER before Viterbi decoding

**Purpose** This measurement gives an indication of the transmission link performance. Due to typical error rates ranging from  $7 \times 10^{-2}$  to  $10^{-5}$  the measurement can be done in a reasonable amount of time. Outside of this range the accuracy of the results may not be guaranteed.

**Interface** The measurement shall be done before the Viterbi decoder (Interface T of the receiver).

**Method** The signal after Viterbi decoding in the measurement instrument is coded again using the same coding scheme as in the transmitter, in order to produce an estimate of the originally coded I and Q sequences. These sequences are compared at bit level with the sign-values of the signals that are available before Viterbi decoding.

The BER for the I and Q paths should be made available separately. The measurement should be based on at least several hundred bit errors. For fast evaluation, in the case that the BER is lower than  $10^{-4}$ , it should be possible to stop the measurement after approximately 1 second.

For accurate measurement of  $E_b/N_0$  at the quasi error free threshold, the measurement time and the presentation of the result should be such that an accuracy of three decimal place can be achieved. The quasi error free threshold corresponds to a BER before Viterbi decoding in the range  $7 \times 10^{-2}$  to  $7 \times 10^{-3}$ , depending on the selected convolutional code rate; or a BER after Viterbi decoding of  $2 \times 10^{-4}$ .

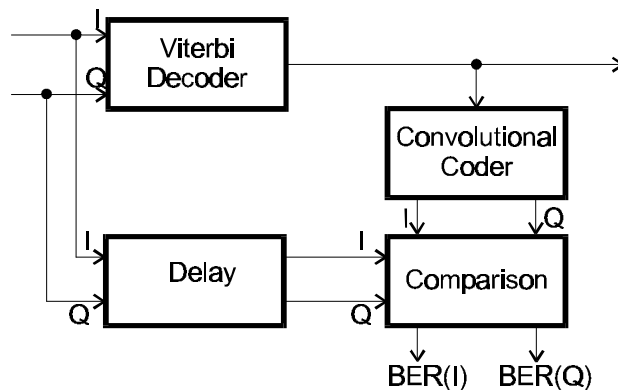

Figure 11: BER measurement before Viterbi decoding

### 8.2 Receive BER vs. $E_b/N_0$

**Purpose** To verify overall clear sky link performance and link margin using a reference down link for acceptance tests.

**Interface** After Viterbi decoding, V

**Method** This is an out-of-service-measurement. The BER measurement shall be based on the null packets inserted at the modulator as defined in clause A.1.

To obtain the various values necessary for the curve BER over  $E_b/N_0$ , white Gaussian noise is injected at the receiver site. In order to get accurate results it shall be verified that the inserted noise level is at least 15 dB above the system noise. This can easily be observed on a spectrum analyser by switching the inserted noise on and off. Stable reception conditions are a precondition for accurate measurement results.

The RS decoding should be deactivated, or bypassed to avoid excessively long measurement periods.

The BER range of interest is  $10^{-9}$  to  $10^{-2}$ .

The measurement values are compared with the theoretical values. The value for the Equivalent Noise Degradation (END) at a BER of  $10^{-4}$  can be derived from this information as well.

For evaluation of  $E_r/N_o$  only the number of information bits (the net bitrate) shall be taken into account.

### **8.3 IF spectrum**

**Purpose** To prevent interference into other channels and to be compliant with the DVB specification the modulator output spectrum shall be according with the one specified in ETS 300 421 [5].

**Interface** H, input of the up-converter, typically 70 MHz or 140 MHz (Modulator output plus equipment for the connection to the up-converter input).

**Method** Spectrum analyser and template for amplitude response, network analyser and template for group delay response, both as specified in ETS 300 421 [5].

## 9 Measurements specific for a terrestrial (DVB-T) system

Intention of this guidelines is to provide a list of measurements useful in a DVB-T OFDM environment. The different options could be selected by the users of the system. The equipment manufacturers (both transmitters and receivers) as well as the operators, can choose those measurements that best fits their needs. A list of the applicability of the measurement parameters described in the present document to the DVB-T transmitter, receiver and network is given in Table 1.

**Table 1: DVB-T measurement parameters and their applicability**

Measurement parameter	Transmitter	Network	Receiver
1) RF frequency accuracy (precision)	X		
2) Selectivity			X
3) AFC capture range			X
4) Phase noise of local oscillators	X		X
5) RF/IF signal power	X		X
6) Noise power			X
7) RF and IF spectrum	X		
8) Receiver sensitivity/ dynamic range for a Gaussian channel			X
9) Equivalent Noise Degradation (END)			X
10) Linearity characterization (shoulder attenuation)	X		
11) Power efficiency	X		
12) Coherent interferer			X
13) BER vs. C/N ratio by variation of transmitter power	X		X
14) BER vs. C/N ratio by variation of Gaussian noise power	X		X
15) BER before Viterbi (inner) decoder			X
16) BER before RS (outer) decoder			X
17) BER after RS (outer) decoder			X
18) I/Q analysis	X		X
19) Overall signal delay	X		
20) SFN synchronization		X	
21) Channel characteristics		X	

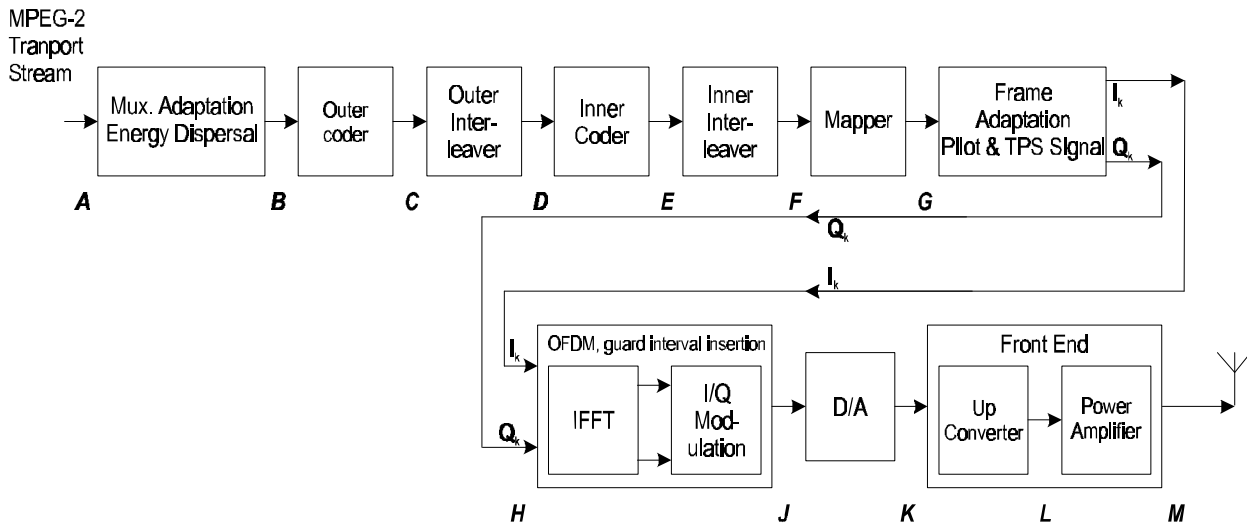

**Figure 12: Block diagram of a DVB-T transmitter**

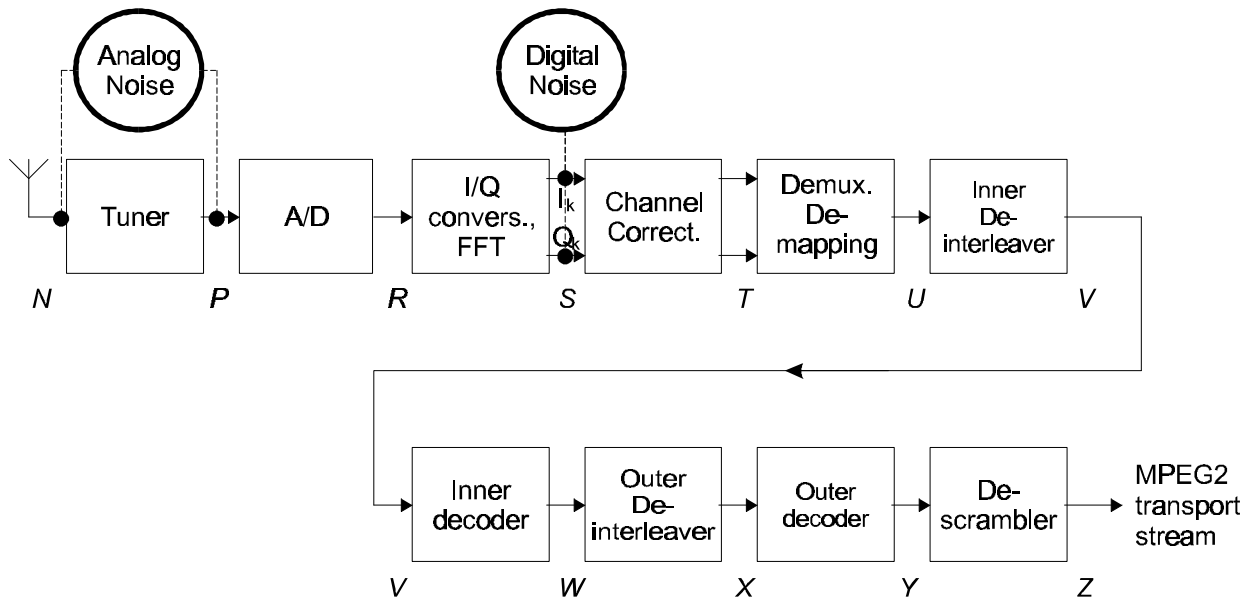

Figure 13: Block diagram of a DVB-T receiver

### 9.1 RF accuracy (precision)

**Purpose** Successful processing of OFDM signals requires that a certain carrier frequency accuracy is maintained at the transmitter. Specific network operations modes such as SFN or co-channel operation with analogue TV services require high accuracy of the carrier frequency.

**Interface** L, M

**Method** The outermost carriers in a DVB-T signal are continuous pilot carriers. Their frequencies are measured (if necessary by utilizing a reference source of sufficient accuracy) and the mean of the two values is calculated.

NOTE: For an 8 k signal the centre carrier No. 3 408 should give the same value.

### 9.2 Selectivity

**Purpose** To identify the capability of the receiver to reject out-of-channel interference.

**Interface** The measurement of the signal input level and the interferer shall be carried out at the interface N, using interface W or X for the BER monitoring.

**Method** The input power is adjusted to 10 dB above the minimum input power as defined in "Receiver sensitivity" (see subclause 9.8). The C/I threshold needed for QEF operation after RS decoder ( $BER < 10^{-4}$  before RS decoder) should be measured as a function of the frequency of a CW interferer.

### 9.3 AFC capture range

**Purpose** To determine the frequency range over which the receiver will acquire overall lock.

**Interface** N, for the application of the test signal; Z, for the test of TS synchronization

**Method** A signal is applied to the input of the receiver, at a level 10 dB above the minimum input power as defined in "Receiver sensitivity" (see subclause 9.8). The signal is frequency shifted in steps towards a nominal value and the Sync\_byte\_error is verified according to subclause 5.2.1 (Measurement and analysis of the MPEG-2 TS - First priority: necessary for decodability (basic monitoring)).

## 9.4 Phase noise of Local Oscillators (LO)

**Purpose** Phase noise can be introduced at the transmitter, at any frequency converter or by the receiver due to unstable local oscillators.

In an OFDM system the phase noise can cause Common Phase Error (CPE) which affects all carriers simultaneously, and which can be corrected by using the continual pilots, and Inter-Carrier Interference (ICI) which is noise-like and that can not be corrected.

The effects of CPE are similar to any single carrier system and the phase noise, outside the loop bandwidth of the carrier recovery circuit, leads to a circular smearing of the constellation points in the I/Q plane. This reduces the operating margin (noise margin) of the system and may directly increase the BER.

The effects of ICI are peculiar to OFDM and cannot be corrected for. This has to be taken into account as part of the total noise of the system.

**Interface** Any access to Local Oscillators (LO), in transmitters, converters and receivers.

**Method** Phase noise can be measured with a spectrum analyser, a vector analyser or a phase noise test set.

**Method for CPE:** Phase noise power density is normally expressed in dBc/Hz at a certain frequency offset from the local oscillator signal. It is recommended to specify a spectrum mask with at least three points (frequency offsets and levels), for example see Figure 14.

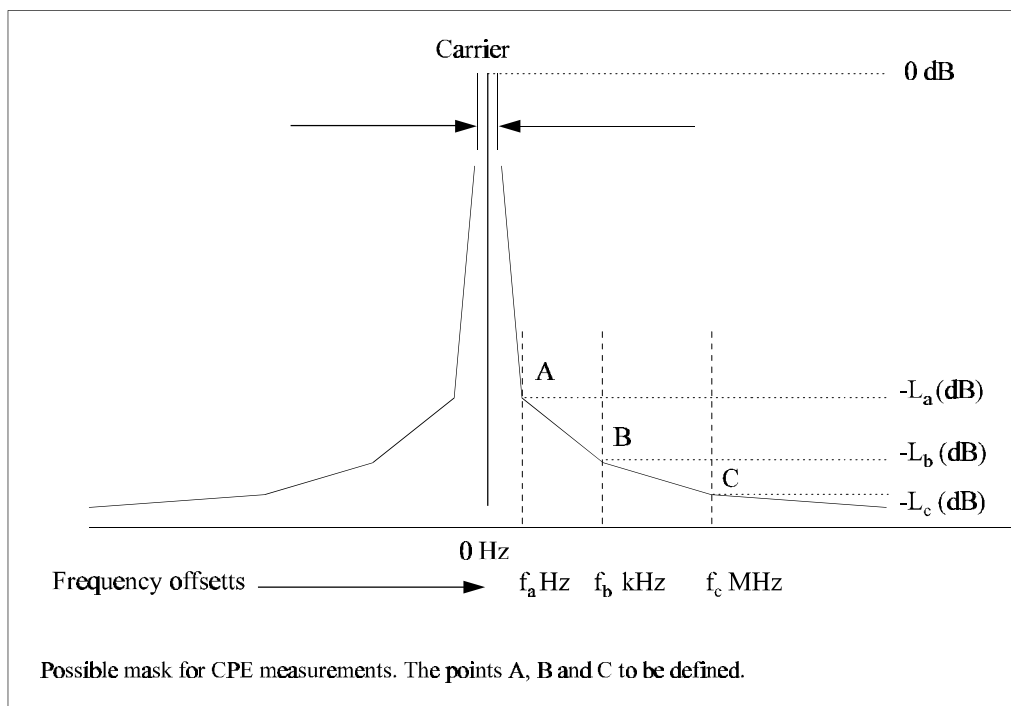

**Figure 14: Possible mask for CPE measurements**

**Method for ICI:** For the measurement of ICI, the use of multiples of the carrier spacing is recommended for the frequencies,  $f_a$ ,  $f_b$ ,  $f_c$ .

**Table 2: Frequency offsets for 2 k and 8 k systems**

Symbol rate:	$f_a$	$f_b$	$f_c$
2 k system	4,5 kHz	8,9 kHz	13,4 kHz
8 k system	1,1 kHz	2,2 kHz	3,4 kHz

**Typical use** For manufacturing, incoming inspection and maintenance of modulators, transmitters, up/down converters and receivers, either professional or consumer type.

### 9.5 RF/IF signal power

**Purpose** Signal power, or wanted power, measurement is required to set and check signal levels at the transmitter and receiver sites.

**Interface** K, L, M, N, P

**Method** The signal power of a terrestrial DVB signal, or wanted power, is defined as the mean power of the signal as would be measured with a thermal power sensor. Care should be taken to limit the measurement to the bandwidth at the wanted signal in case of received signals. When using a spectrum analyser or a calibrated receiver, it should integrate the signal power within the nominal bandwidth of the signal ( $n \times f_{\text{SPACING}}$ ).

### 9.6 Noise power

**Purpose** Noise is a significant impairment in a transmission network.

**Interface** N,P

**Method** The noise power (mean power), or unwanted power, can be measured with a spectrum analyser (out of service). The noise power is specified using the occupied bandwidth of the OFDM signal ( $n \times f_{\text{SPACING}}$ ).

NOTE: The term C/N should be calculated as the ratio of the signal power, measured as described in subclause 9.6, to the noise power, measured as described in this subclause.

### 9.7 RF and IF spectrum

**Purpose** To avoid interfering with other channels, the transmitted RF spectrum should comply to a spectrum mask, which is defined for the terrestrial network. If the spectrum at the modulator output is defined by a spectrum mask, the same procedure can be applied to the IF signal (with no pre-correction active).

**Interface** K, M

**Method** This measurement is usually carried out using a spectrum analyser. The spectral density of a terrestrial DVB signal is defined as the long-term average of the time-varying signal power per unity bandwidth (i.e. 1 Hz). Values for other bandwidths can be achieved by proportional increase of the values for unity bandwidth.

To avoid regular structures in the modulated signal a non-regular, e.g. a Pseudo-Random Binary Sequence (PRBS) -like or a programme type digital transmitter input signal is necessary.

Care has to be taken that the input stage of the selective measurement equipment is not overloaded by the main lobe of the signal while assessing the spectral density of the side lobes, i. e. the out-of-band range. Especially in cases with very strong attenuation of the side lobes non-linear distortion in the measurement equipment can produce side lobe signals that mask the original ones. Selective attenuation of the main lobe has proven to be in principal a way to avoid this masking effects. However, as the frequency response of the band-stop filter has to be included in the evaluation, the whole measurement procedure may become somewhat complex.

### 9.8 Receiver sensitivity/dynamic range for a Gaussian channel

**Purpose** For network planning purposes, the minimum and maximum input powers for normal

operation of a receiver have to be determined.

**Interface** Test signals are applied and measured at interface N; interfaces W or X are used for the monitoring of BER before RS.

**Method** The minimum and maximum input power for QEF (Quasi Error Free) operation after the RS decoder (i.e.  $BER < 10^{-4}$  before RS decoding) shall be measured. The dynamic range is the difference of both values.

### 9.9 Equivalent Noise Degradation (END)

**Purpose** END is a measure of the implementation loss caused by the network or the equipment where the reference is the ideal performance.

**Interface** W or X for BER measurement; N, P or S for noise injection

**Method** The END is obtained from the difference in dB of the C/N ratio needed to reach a BER of  $2 \times 10^{-4}$  before RS (outer) decoding, and the C/N ratio that would theoretically give a BER of  $2 \times 10^{-4}$  for a Gaussian channel (see annex A of ETS 300 744 [9]).

### 9.10 Linearity characterization (shoulder attenuation)

**Purpose** The "shoulder attenuation" can be used to characterize the linearity of an OFDM signal without reference to a spectrum mask.

**Interface** M

**Method** Apply the following procedure on the measured RF spectrum of the transmitter output signal:

(a) Identify the maximum value of the spectrum by using a resolution bandwidth at approximately 10 times the carrier spacing.

(b) Place declined, straight lines connecting the measurement points at 300 kHz and 700 kHz from each of the upper and lower edges of the spectrum. Draw additional lines parallel to these, so that the highest spectrum value within the respective range lies on the line.

(c) Subtract the power value of the centre of the line (500 kHz away from the upper and lower edge) from the maximum spectrum value of (a) and note the difference as the "shoulder attenuation" at the upper and lower edge.

(d) Take the worst case value of the upper and lower results from (c) as the overall "shoulder attenuation".

### 9.11 Power efficiency

**Purpose** To compare the overall efficiency of DVB transmitters.

**Interface** M

**Method** Power efficiency is defined as the ratio of the DVB output power to the total power consumption of the chain from TS input to the RF signal output including all necessary equipment for operation such as blowers, transformers etc. The operational channel and the environmental conditions need to be specified.

### 9.12 Coherent interferer

**Purpose** To identify any coherent interferer which may influence the reliability of the I/Q analysis or the BER measurements.

<b>Interface</b>	N or P
<b>Method</b>	The measurement is carried out with a spectrum analyser. The resolution bandwidth is reduced stepwise so that the displayed level of the modulated carriers ( <i>and of the unmodulated pilots, due to the influence of the guard interval</i> ) is reduced. The CW interferer is not affected by this process and can be identified after appropriate averaging of the trace.

### 9.13 BER vs. C/N ratio by variation of transmitter power

**Purpose** To evaluate the BER performance of a transmitter as the Carrier to Noise (C/N) ratio is varied, with the measurement repeated for a range of mean transmitted output powers. This measurement can be used to compare the performance of a transmitter with theory or with other transmitters.

**Interface** From F to U or from E to V

**Method** A Pseudo-Random Binary Sequence (PRBS) is injected at interface F (or E). The various C/N ratios are established at the input of the test receiver by addition of Gaussian noise, and the BER of the received PRBS is measured at point V (or U) using a BER TEST Set. The measurement is repeated for a range of mean transmitted output power.

If the ability to generate a PRBS at interface F (or E) is included in the transmitting equipment for test purposes, then it should be a  $2^{23}-1$  PRBS as defined by ITU-T Recommendation O.151 [12].

For the measurement of carrier and noise power, the system bandwidth is defined as  $n \times f_{\text{SPACING}}$ , where  $n$  is the number of active carriers (e.g. 6 817 or 1 705 carriers in an 8 MHz channel) and  $f_{\text{SPACING}}$  is the frequency spacing of the OFDM carriers.

NOTE: Transmitter back-off is defined as the ratio of the rated pulsed peak power of the transmitter to the mean power of the signal. The rated pulsed peak power is normally equivalent to the peak sync power of a standard B, D, G, H, I or K RF signal.

### 9.14 BER vs. C/N ratio by variation of Gaussian noise power

**Purpose** To evaluate the BER performance of a receiver as the Carrier to Noise (C/N) ratio is varied by changing the added Gaussian noise power. This measurement can be used to compare the performance of a receiver with theory or with other receivers. For example to evaluate the influence of receiver noise floor.

**Interface** From F to U or from E to V

**Method** A Pseudo-Random Binary Sequence (PRBS) is injected at interface F (or E). Various C/N ratios are established at the input of the receiver under test by addition of Gaussian noise and the BER of the received PRBS is measured at point V (or U) using a BER test set.

A test transmitter should be able to generate the  $2^{23}-1$  PRBS as defined by ITU-T Recommendation O.151.[12].

For the measurement of carrier and noise power, the system bandwidth is defined as  $n \times f_{\text{SPACING}}$  where  $n$  is the number of active carriers (e.g. 6 817 or 1 705 carriers in an 8 MHz channel) and  $f_{\text{SPACING}}$  is the frequency spacing of the OFDM carriers.

NOTE: The bandwidth in an 8 MHz channel is 7,61 MHz, and in a 7 MHz channel system it is 6,66 MHz.

### 9.15 BER before Viterbi (inner) decoder

**Purpose** This measurement gives an in-service indication of the un-coded performance of the

transmitter, channel and receiver.

**Interface** V

**Method** The signal after Viterbi decoding in the test receiver is coded again using the same convolutional coding scheme as in the transmitter in order to produce an estimate of the originally coded data stream. This data stream is compared at bit-level with the signal which is available before Viterbi decoder.

The measurement should be based on at least several hundred bit errors.

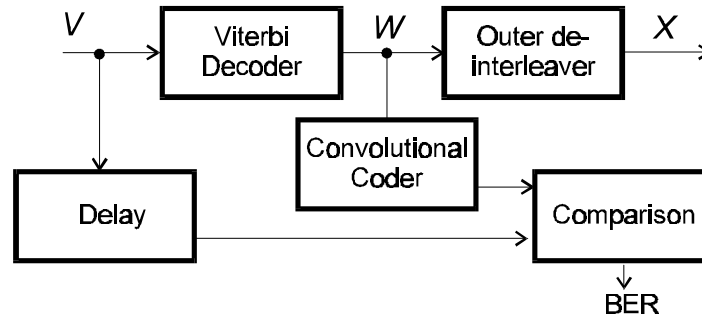

**Figure 15: BER measurement before Viterbi decoding**

### 9.16 BER before RS (outer) decoder

**Purpose** The BER is the primary parameter which describes the quality of the digital transmission link.

**Interface** W or X

**Method** The BER is defined as the ratio between erroneous bits and the total number of transmitted bits.

Two alternative methods are available; one for "Out of Service" and a second for "In Service" use. In both cases, the measurement should only be done within the Link Available Time (LAT) as defined in subclause 6.2.

#### 9.16.1 Out of Service

The basic principle of this measurement is to generate within the channel encoder a known, fixed, repeating sequence of bits, essentially of a Pseudo-Random nature. In order to do this the data entering the sync-inversion/randomization function is a continuous repetition of one fixed TS packet. This sequence is defined as the *null TS packet* in ISO/IEC 13818-1 [1] with all data bytes set to 0x00; i.e. the fixed packet is defined as the four byte sequence 0x47, 0x1F, 0xFF, 0x10, followed by 184 zero bytes (0x00). Ideally this would be available as an encoding system option.

*The apparently obvious alternative of injecting a PRBS in the transmitter at the output of the RS encoder is not used because of the requirement to have sync bytes to ensure correct operation of the byte interleaver. Insertion after the byte interleaver is not appropriate because it is not then directly comparable with the in-service measurement.*

#### 9.16.2 In Service

The basic assumption made in this measurement method is that the RS check bytes are computed for each link in the transmission chain. Under normal operational circumstances, the RS decoder will correct all errors and produce an error-free TS packet. If there are severe error-bursts, the RS decoding algorithm may be overloaded, and be unable to correct the packet. In this case the transport\_error\_indicator bit shall be set, no other bits in the packet shall be changed, and the 16 RS check bytes shall be recalculated accordingly before re-transmission on to another link. The BER measured at any point in the

transmission chain is then the BER for that particular link only.

The number of erroneous bits within a TS packet will be estimated by comparing the bit pattern of this TS packet before and after RS decoding. If the measured value of BER exceeds  $10^{-3}$  then the measurement should be regarded as unreliable due to the limits of the RS decoding algorithm. Any TS packet that the RS decoder is unable to correct should cause the calculation to be restarted.

### 9.17 BER after RS (outer) decoder

**Purpose** To measure whether the MPEG-2 TS is quasi error free.

**Interface** Z

**Method** The same principle as used for the "Out of service" measurement of the "BER before the RS decoder" described in subclause 9.16.1, with the modification that the result is presented as an error count rather than a ratio. The receiver only has to compare the received TS packets with the Null packets as defined in subclause A.1.2.

### 9.18 IQ signal analysis

#### 9.18.1 Introduction

The IQ analysis can be applied on single carriers of the OFDM signal as well as on groups of carriers. If groups of carriers are under consideration all received symbols of this group can be superimposed in order to get one common constellation diagram. Since the scattered pilot carriers, the continual pilot carriers and the TPS carriers are transmitted in a different modulation scheme it is recommended to exclude these carriers from the IQ analysis or apply a specific IQ analysis.

Assuming:

- a constellation diagram of M symbol points and K carriers under consideration with  $0 < K \leq K_{MAX}$  and  $K_{MAX}$  is the total number of active OFDM carriers;
- a measurement sample of N data points, where N is sufficiently larger than  $M \times K$  to deliver the wanted measurement accuracy; and
- the co-ordinates of each received data point j being  $I_j + \delta I_j$ ,  $Q_j + \delta Q_j$  where I and Q are the co-ordinates of the ideal symbol point and  $\delta I$  and  $\delta Q$  are the offsets forming the error vector of the data point (as long as the respective carrier is a "useful" one).

Six parameters can be calculated, which give an in-depth analysis of different influences, all deteriorating the signal.

Modulation Error Ratio (MER) and the related Error Vector Magnitude (EVM) are calculated from all N data points without special pre-calculation for the data belonging to the M symbol points.

With the aim of separating individual influences from the received data, for each point i of the M symbol points the mean distance  $d_i$  and the distribution  $\sigma_i$  can be calculated from those  $\delta I_j$ ,  $\delta Q_j$  belonging to the point i.

From the M values  $\{d_1, d_2, \dots, d_M\}$  the influences/parameters:

- Origin offset (only for centre carrier: 3 408 for 8 k mode, 852 for 2 k mode);
- Amplitude Imbalance; and
- Quadrature Error (QE)

can be extracted and removed from the  $d_i$  values, allowing to calculate the Residual Target Error (RTE) with the same algorithm as the System Target Error (STE) from  $\{d_1, d_2, \dots, d_M\}$ .

From the statistical distribution of the M clouds the parameters:

- Phase Jitter (PJ); and
- coherent interferer

may be extracted. The remaining clouds (after elimination of the above two influences) are assumed to be due to Gaussian noise only and are the basis for calculation of the signal-to-noise ratio. The parameter may include - besides noise - also some other disturbing effects, like small coherent interferers or residual errors from the channel correction.

When using the interfaces S or T filtering of the signal before the interface should be considered.

### 9.18.2 Modulation Error Ratio (MER)

**Purpose** To provide a single "figure of merit" analysis of the K carriers.

**Interface** S, T and H

**Method** The carrier frequency of the OFDM signal and the symbol timing are recovered. Origin offset of the centre carrier (e.g. caused by residual carrier or DC offset), Quadrature Error (QE) and Amplitude Imbalance are not corrected.

A time record of N received symbol co-ordinate pairs  $(\tilde{I}_j, \tilde{Q}_j)$  is captured.

For each received symbol, a decision is made as to which symbol was transmitted. The error vector is defined as the distance from the ideal position of the chosen symbol (the centre of the decision box) to the actual position of the received symbol.

This distance can be expressed as a vector  $(\delta I_j, \delta Q_j)$ .

The sum of the squares of the magnitudes of the ideal symbol vectors is divided by the sum of the squares of the magnitudes of the symbol error vectors. The result, expressed as a power ratio in dB, is defined as the MER.

$$MER = 10 \times \log_{10} \left\{ \frac{\sum_{j=1}^N (I_j^2 + Q_j^2)}{\sum_{j=1}^N (\delta I_j^2 + \delta Q_j^2)} \right\} dB$$

It should be reconsider that MER is just one way of computing a "figure of merit" for a vector modulated signal. Another "figure of merit" calculation is Error Vector Magnitude (EVM) defined in annex C of the present document. It is also shown in annex C that MER and EVM are closely related and that one can generally be computed from the other.

MER is the preferred first choice for various reasons itemized in annex C of the present document.

### 9.18.3 System Target Error (STE)

**Purpose** The displacement of the centres of the clouds in a constellation diagram from their ideal symbol point reduces the noise immunity of the system and indicates the presence of special kinds of distortions such as Amplitude Imbalance and Quadrature Error (QE). STE gives a global indication about the overall distortion present on the raw data received by the system.

**Interface** S and T

**Method**

For each of the  $M$  symbol points in a constellation diagram compute the distance  $d_i$  between the theoretical symbol point and the point corresponding to the mean of the cloud of this particular symbol point. This quantity ( $\bar{d}_i$ ) is called Target Error Vector (TEV) and is shown in Figure 16.

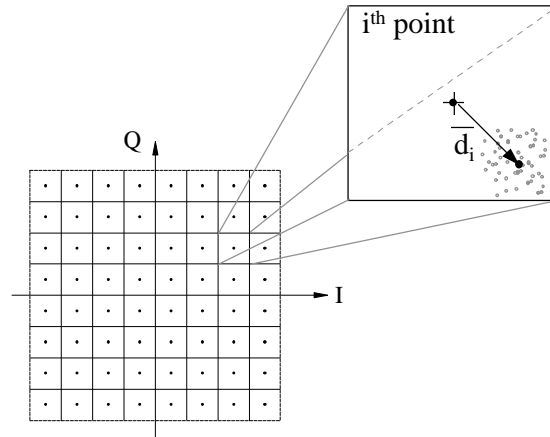

**Figure 16: Definition of Target Error Vector (TEV)**

From the magnitude of the  $M$  Target Error Vectors (TEV) calculate the mean value and the standard deviation (normalized to  $S_{rms}$ , defined as the RMS amplitude value of the points in the constellation), obtaining the System Target Error Mean (STEM) and the System Target Error Deviation (STED) as follows:

$$TEV = \bar{d}_i = (\delta\bar{I}_i, \delta\bar{Q}_i) \quad \text{for all } j = 1, 2, \dots, N_s \text{ data points belonging to the sub-symbol } i;$$

$$\text{with } \delta\bar{I}_i = \frac{1}{N_s} \sum_{j=1}^{N_s} \delta I_j \quad \text{and} \quad \delta\bar{Q}_i = \frac{1}{N_s} \sum_{j=1}^{N_s} \delta Q_j$$

$$S_{rms} = \sqrt{\frac{1}{N} \sum_{j=1}^N (I_j^2 + Q_j^2)}$$

$$STEM = \frac{1}{M \times S_{rms}} \sum_{i=1}^M |\bar{d}_i|$$

$$STED = \sqrt{\frac{\sum_{i=1}^M |\bar{d}_i|^2}{M \times S_{rms}^2} - STEM^2}$$

#### 9.18.4 Carrier Suppression (CS)

**Purpose**

A residual carrier is an unwanted coherent signal added to the centre carrier of the OFDM signal. It may have been produced by dc offset voltages of the modulating I and/or Q signal or by crosstalk from the modulating carrier within the modulator.

**Interface**

S and T

**Method** Search for systematic deviations of all constellation points of the centre carrier and isolate the residual carrier. Calculate the Carrier Suppression (CS) from the formula:

$$CS = 10 \times \log_{10} \left( \frac{P_{sig}}{P_{RC}} \right)$$

where  $P_{RC}$  is the power of the residual carrier and  $P_{sig}$  is the power of the centre carrier of the OFDM signal (without residual carrier).

### 9.18.5 Amplitude Imbalance (AI)

**Purpose** To separate the QAM distortions resulting from Amplitude Imbalance (AI) of the I and Q signal from all other kind of distortions.

**Interface** S and T

**Method** Calculate the I and Q gain values  $v_I$  and  $v_Q$  from all points in a constellation diagram eliminating all other influences.

Calculate Amplitude Imbalance (AI) from  $v_I$  and  $v_Q$ :

$$v_I = \frac{1}{M} \sum_{i=1}^M \frac{I_i + (\bar{d}_i)_I}{I_i}$$

$$(\bar{d}_i)_I = \frac{1}{N} \sum_{j=1}^N \delta I_j \quad (\text{I - component of } d_i \text{ as given in subclause 9.19.3 System Target Error})$$

$$v_Q = \frac{1}{M} \sum_{i=1}^M \frac{Q_i + (\bar{d}_i)_Q}{Q_i}$$

$$(\bar{d}_i)_Q = \frac{1}{N} \sum_{j=1}^N \delta Q_j \quad (\text{Q - component of } d_i \text{ as given in subclause 9.19.3 System Target Error})$$

$$(\bar{d}_i)_I + (\bar{d}_i)_Q = \bar{d}_i$$

### 9.18.6 Quadrature Error (QE)

**Purpose** The phases of the two carriers feeding the I and Q modulators have to be orthogonal. If their phase difference is not 90 a typical distortion of the constellation diagram results.

*It is assumed that the value derived from the centre carrier is representative for the whole signal.*

**Interface** S and T

**Method** Search for the constellation diagram error shown in Figure 17 and calculate the absolute value of the phase difference  $\Delta\phi = |\phi_1 - \phi_2|$  after having eliminated all other influences and convert this into degrees:

$$QE = \frac{180^\circ}{\pi} \times |\phi_1 - \phi_2| [^\circ].$$

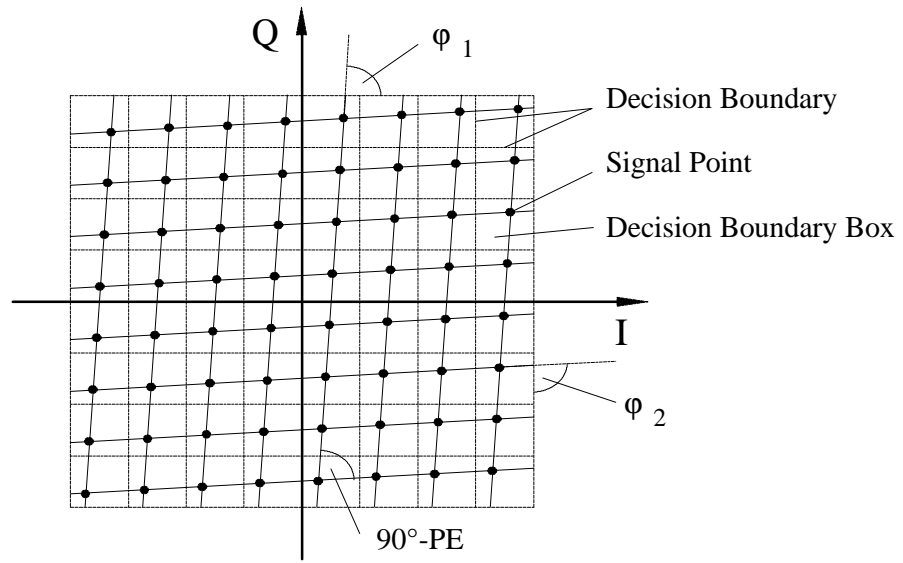

**Figure 17: Distortion of constellation diagram resulting from I/Q Quadrature Error (QE)**

**9.18.7 Phase Jitter (PJ)**

**Purpose**

The PJ of an oscillator is due to fluctuations of its phase or frequency. Using such an oscillator to modulate a digital signal results in a sampling uncertainty in the receiver, because the carrier regeneration cannot follow the phase fluctuations.

The signal points are arranged along a curved line crossing the centre of each decision boundary box as shown in Figure 18 for the four "Corner Decision Boundary Boxes".

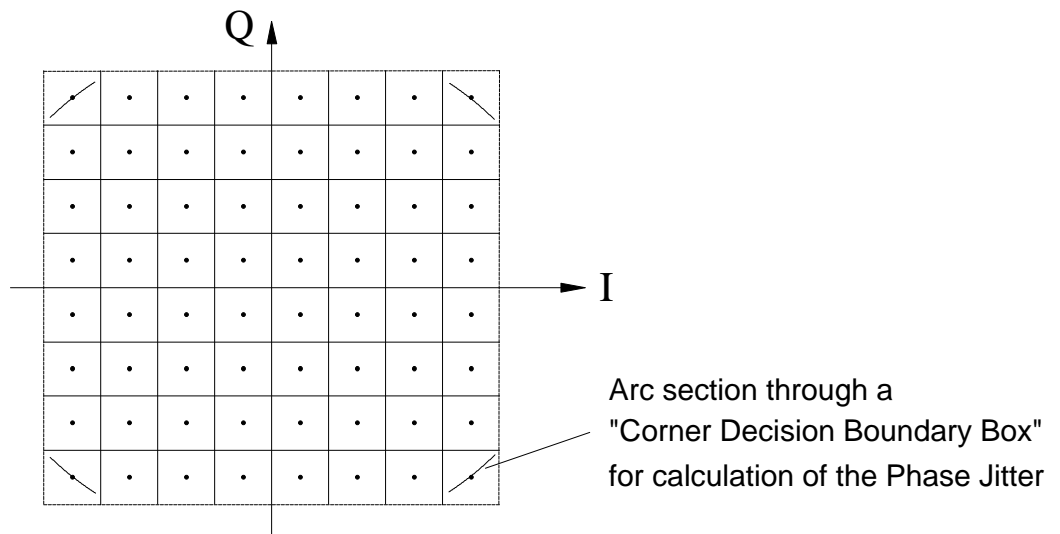

**Figure 18: Position of "Arc section" in the constellation diagram to define PJ (example: 64-QAM)**

**Interface** S and T

**Method** Phase Jitter can be calculated theoretically using the following algorithm:

1) Calculate the angle between the I-axis of the constellation and the vector to the received symbol ( $I_{rcvd}, Q_{rcvd}$ ):

$$\phi_1 = \arctan \frac{Q_{rcvd}}{I_{rcvd}}$$

2) Calculate the angle between the I-axis of the constellation and the vector to the corresponding ideal symbol ( $I_{ideal}, Q_{ideal}$ ):

$$\phi_2 = \arctan \frac{Q_{ideal}}{I_{ideal}}$$

3) Calculate the error angle:

$$\phi_E = \phi_1 - \phi_2$$

4) From these N error angles calculate the RMS phase jitter:

$$PJ = \sqrt{\frac{1}{N} \sum_{i=1}^N \phi_{E_i}^2 - \frac{1}{N^2} \left( \sum_{i=1}^N \phi_{E_i} \right)^2}$$

However, the following method may be more practical:

The first approximation of the "Arc Section" of a "Corner Decision Boundary Box" is a straight line parallel to the diagonal of the "Decision Boundary Box". Additionally the curvature of the Phase Jitter (PJ) trace has to be taken into account when calculating the standard deviation of the PJ. The mean value of the PJ is calculated in degrees.

$$PJ = \frac{180^\circ}{\pi} \times \arcsin \left( \frac{\sigma_{PJ}}{\sqrt{2} \times (\sqrt{M} - 1) \times d} \right) [^\circ]$$

where M = Order of QAM

and 2d = Distance between two successive boundary lines

Within the argument of the arc sine function, the standard deviation of the Phase Jitter is referenced to the distance from the centre of the "Corner Decision Boundary Box" to the centre point of the QAM signal.

## 9.19 Overall signal delay

**Purpose** To measure and adjust the signal delay of an OFDM transmitter to a given value so that the transmitters in an SFN can be synchronized.

**Interface** A, M

**Method** (a) The total delay between the MPEG TS input of the transmitter under test and the MPEG TS output of a test receiver is established by measuring the time delay required to match the input and output data patterns. If the delay of the test receiver

is known then the transmitter signal delay can be derived.

Alternatively, the delay of the test receiver could be expressed relative to the delay of a reference receiver. This would avoid the need to measure the absolute delay of any receiver.

- (b) A more direct method may be to define a transmitter test mode in which the occurrence of a Mega-frame Initialization Packet (MIP) at the MPEG TS input causes a trigger pulse (see TS 301 191 [14]).

The trigger pulse is made available for connection to an oscilloscope and also used to "arm" the modulator. At the start of the next mega-frame the modulator transmits a null symbol (or a defined pulse in the time domain) rather than the normal data. The delay between the trigger pulse and the RF null (or pulse) is measured.

## **9.20 SFN synchronization**

*To be defined.*

## **9.21 Channel characteristics**

*To be defined.*

## Annex A: General measurement methods

### A.1 Introduction

It is recommended that manufacturers add the test mode described in this annex to certain professional grade cable and satellite broadcast equipment. This recommendation is relevant to equipment that implements the channel encoding schemes defined in ETS 300 429 [6] (cable) and ETS 300 421 [5] (satellite).

The purpose of the recommended test mode is to simplify out of service testing of systems and system components by making the channel encoder able to generate a known, fixed, repeating bit sequence of an essentially pseudo-random nature.

The central requirement is that when the channel encoder is in the test mode, the data entering the sync inversion/randomization function is a continuous repetition of one fixed TS packet. The fixed packet is defined as the four byte sequence 0x47, 0x1f, 0xff, 0x10, followed by 184 zero bytes (0x00). This form of data is a refinement of the *null TS packet* definition in ISO/IEC 13818-1 [1].

### A.2 Null packet definition

This clause summarizes the null packet definition from ISO/IEC 13818-1 [1] and then describes how the definition has been extended for the purpose of the recommended test mode.

ISO/IEC 13818-1 [1] defines a null TS packet for the purposes of data rate stuffing.

Table 1 shows the structure of a null TS packet using the method of describing bit stream syntax defined in subclause 2.4.3.3. of ISO/IEC 13818-1 [1].

This description is derived from tables 2-3 Transport Header (TH) in ISO/IEC 13818-1 [1]. The abbreviation "bslbf" means "bit string, left bit first", and "uimsbf" means "unsigned integer, most significant bit first".

The column titled "Value", gives the bit sequence for the recommended null packet.

A null packet is defined by ISO/IEC 13818-1 [1] as having:

- payload\_unit\_start\_indicator = "0";
- **PID** = 0x1FFF;
- **transport\_scrambling\_control** = "00";
- **adaptation\_field\_control** value = "01". This corresponds to the case "*no adaptation field, payload only*".

The remaining fields in the null packet that shall be defined for testing purposes are:

- **transport\_error\_indicator** which is "0" unless the packet is corrupted. For testing purposes this bit is defined as "0" when the packet is generated;
- **transport\_priority** which is not defined by ISO/IEC 13818-1 for a null packet. For testing purposes this bit is defined as "0";
- **continuity\_counter** which ISO/IEC 13818-1 states is undefined for a null packet. For testing purposes this bit field is defined as "0000";
- **data\_byte** which ISO/IEC 13818-1 states may have any value in a null packet. For testing purposes this bit field is defined as "00000000".

**Table A.1: Null TS packet definition**

Syntax	No. of bits	Identifier	Value
null_transport_packet(){			
sync_byte	8	bslbf	"01000111"
transport_error_indicator	1	bslbf	"0"
payload_unit_start_indicator	1	bslbf	"0"
transport_priority	1	bslbf	"0"
PID	13	uimsbf	"11111111111111"
transport_scrambling_control	2	bslbf	"00"
adaptation_field_control	2	bslbf	"01"
continuity_counter	4	uimsbf	"0000"
for (l = 0; l < N; l++) {			
data_byte	8	bslbf	"00000000"
}			
}			

### A.3 Description of the procedure for "Estimated Noise Margin" by applying statistical analysis on the constellation data

Instead of adding real noise to the received signal this method uses statistical analysis and an iterative search algorithm to estimate the added noise power to reach the critical BER.

- 1) Demodulate the signal to produce a statistically significant sequence of data records. Each record represents the state of the demodulated I and Q components at a decision instant.
- 2) Compute the average noise power as the mean square of the error vectors and calculate the estimated  $S_{avg} / N_{avg}$  ratio.

$$SNR = 10 \times \log_{10} \left( \frac{\frac{1}{N} \sum_{j=1}^N (I_j^2 + Q_j^2)}{\frac{1}{N} \sum_{j=1}^N (\sigma I_j^2 + \sigma Q_j^2)} \right)$$

The  $\sigma I_j$  and  $\sigma Q_j$  are the error vector co-ordinates which represent the offset from the co-ordinates of the centre (mean value) of the actual received data for a specific constellation point, to the actual received data point j (see also Figure 6).

If only Gaussian noise is present as an impairment the "centre (mean value) of the actual received data for a specific constellation point" is identical to the ideal symbol point.

N is the number of data points in the measurement sample.

- 3) Compute the additional noise power  $N_{step}$  required to degrade the computed SNR by a certain amount. The value  $N_{step}$  is usually determined by the iterative optimization procedure which is used.

- 4) For each data record in the sample compute the distances  $d$  from the true position of the signal at the decision instant to each of the decision boundaries with adjacent cells. For each of the directions +I, -I, +Q, -Q that would cause a symbol error, convert the distance to the decision boundary into the number of standard deviations ( $k$ ) of a normal distribution with a variance corresponding to the added noise power. The variance of the added noise power is:

$$\sigma^2 = N_{step}$$

and the normalized standard deviation corresponding to the distance  $d_{I+}$  is for example:

$$k_{I+} = \frac{\sigma}{d_{I+}}$$

- 5) Compute the probability  $Q_s$  of a symbol error for each distribution tail due to an erroneous state transition in the relevant direction.

$$Q_s(k) = \frac{1}{\sqrt{2\pi}} \int_k^{\infty} \exp\left(-\frac{x^2}{2}\right) dx$$

or

$$Q_s(k) = \frac{1}{2} \operatorname{erfc}\left(\frac{k}{\sqrt{2}}\right)$$

- 6) Compute the number of bit errors that the erroneous state transition would cause and calculate the bit error probability  $Q_B$ . One symbol error may result in more than one bit error for transitions across either the I or Q axis. Sum the individual  $Q_B$  values and divide by the number of points in the sample to get the average probability of a bit error.
- 7) Repeat the steps 4 to 6 for incremental values of noise power until the critical BER is found and calculate the noise margin:

$$\text{Noise Margin (dB)} = 10 \times \log_{10} \left( 1 + \frac{N_{added}}{N_{avg}} \right)$$

#### A.4 Set-up for RF phase noise measurements using a spectrum analyser

The noise performance of the carrier can be characterized as the ratio of the measured power in one noise sideband component, on a per hertz of bandwidth spectral density basis, to the total signal power:

$$\alpha(f_m) = 10 \times \log_{10} \left( \frac{\text{power\_density(one\_sideband,phase\_only)}}{\text{power\_of\_total\_signal}} \right)$$

in (dBc/Hz) and  $f_m$  is the frequency distance away from the carrier.

For this measurement it is assumed that contributions from amplitude modulation to the noise spectrum are negligible compared to those from frequency modulation and that  $\Delta B$ , the measurement bandwidth, is much smaller than  $f_m$ . A spectrum analyser with a noise measurement option is able to measure the power within 1 Hz bandwidth. If this is not available the resolution bandwidth should be as small as possible and the video bandwidth has to be 10 or 20 times smaller in order to get sufficient averaging of the noise over time.

For example: carrier frequency: 36 MHz  
 $f_m = 10$  kHz  
 $\Delta B =$  Equivalent Noise Bandwidth (ENB) of the resolution bandwidth filter: 270 Hz  
 video bandwidth: 10 Hz or 30 Hz

NOTE 1: Spectrum analysers typically use near Gaussian filters for the resolution bandwidth with a 20 % tolerance. The Equivalent Noise Bandwidth (ENB) is equal to the bandwidth of the filter measured at -3,4 dB, (by actually measuring the filter of the spectrum analyser, the 20 % tolerance factor is eliminated).

Then the following conversion to 1 Hz bandwidth can be applied:

$$\alpha(f_m) \cong 10 \times \log_{10} \left( \frac{\text{noise\_power\_in\_DB}}{\text{signal\_power}} \right) - 10 \times \log_{10} \Delta B + 2,5 \text{ dB} \quad \text{in [dBc/Hz]}$$

NOTE 2: The 2,5 term accounts for the correction of 1,05 dB due to narrowband envelope detection and the 1,45 dB due to the logarithmic amplifier.

Having measured  $\alpha(f_m)$  for various values of  $f_m$  an estimation of equivalent peak phase deviation and frequency deviation is possible by using sinusoidal analogy:

$$\alpha(f_m) \cong 20 \times \log_{10} (\Delta\phi_{\text{rms}} / \sqrt{2}) \quad \text{in [dB/Hz]}$$

with  $\Delta\phi$  in [rad/Hz]

The square root of the sum of all noise densities within the frequency range of interest will give the equivalent RMS phase noise error vector in the I/Q plane.

An estimation can be done if the phase noise power slope may be approximated by the density function:

$$Y = a \frac{1}{f^b} [W/Hz]$$

$$\text{with } b = \frac{\text{slope[dB]}_{\text{per decade}}}{10} \quad (b > 0) \quad \text{and}$$

$$a = N_0 \times f_1^b \quad \text{where } N_0 = 10^{\left( \frac{\alpha(f_1)}{10} \right)}$$

Then the total double-side-band phase noise power within the frequency range of interest ( $f_1, f_2$ ) can be approximated by:

$$DSB - \text{Phase} - \text{Noise} = 2a \int_{f_1}^{f_2} \frac{1}{f^b} df = \frac{2a}{(b-1)} \left( \frac{1}{f_1^{(b-1)}} - \frac{1}{f_2^{(b-1)}} \right)$$

For the normalized RMS error vector (carrier = 1) it follows:

$$\text{RMS Quadrature Error Vector} = \sqrt{\frac{2a}{(b-1)} \left( \frac{1}{f_1^{(b-1)}} - \frac{1}{f_2^{(b-1)}} \right)} = \sigma_{ph}$$

$$\Delta\phi_{\sigma} \cong \arctan \sigma_{ph} [rad] \quad (\text{for carrier} = 1)$$

## A.5 Amplitude, phase and impulse response of the channel

The amplitude, phase and impulse response can be derived from the equalizer tap coefficients. The use of a good equalizer that is designed to cope with the echo profile defined in clause B.14 is recommended to get accurate results in case of high linear distortions.

The capabilities to derive the channel response from the equalizer tap coefficients depend on the structure of the equalizer. Especially the channel response in the Nyquist slope of the signal can not be measured exactly with a T-spaced equalizer.

## A.6 Out of band emissions

The out of band emissions can be measured using a spectrum analyser. The resolution bandwidth shall be low enough to detect peaks in the out of band spectrum. The video filter signal shall be at least 10 times lower than the resolution bandwidth for sufficient averaging of the noise-like signal.

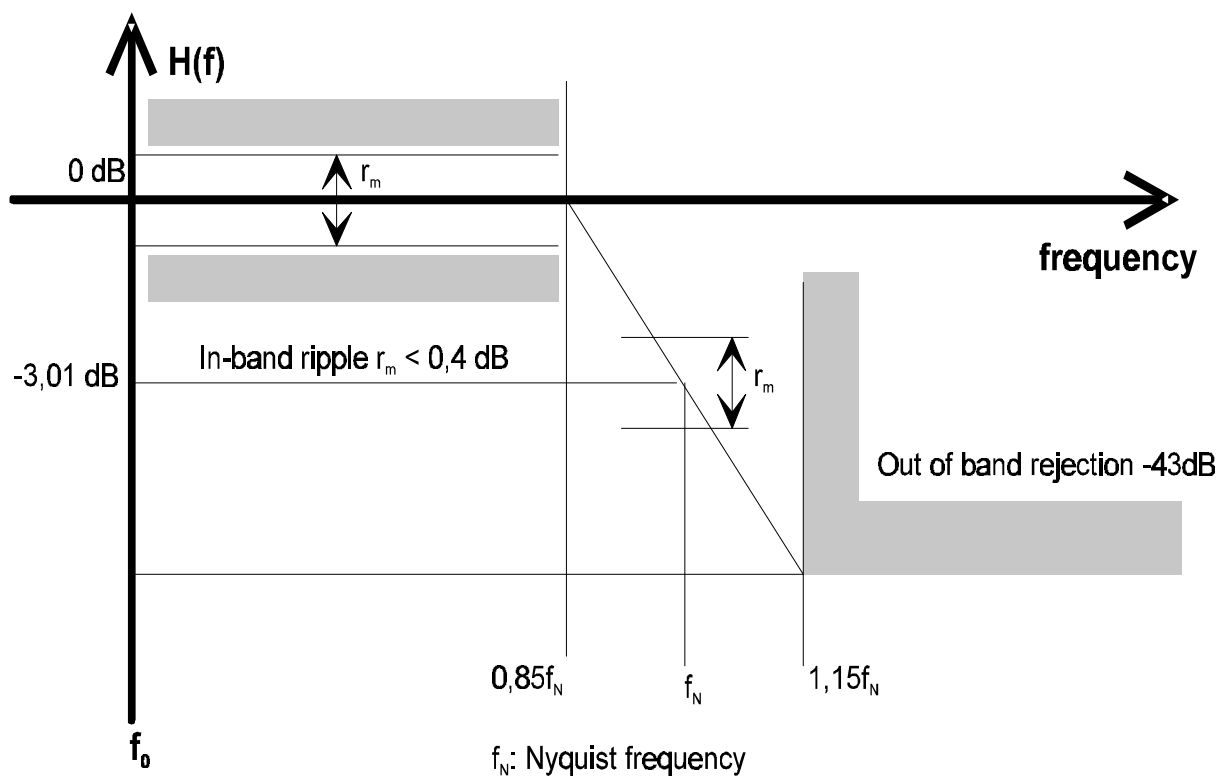

Figure A.1: Spectrum mask as defined in ETS 300 429 [6]

## Annex B: Examples for test set-up

Even if not demonstrated in the diagrams of this clause and also not mentioned in the explanations the receiver may be a part of the measurement device. In this case all the interfaces defined in Figure 2 are internal ones, where the measurement device has access to.

### B.1 System availability

See subclause 6.1.

Because this measurement is based on the `error_indicator_flag` in the TS header set in any previous stage including the last stage of the transmission chain the signal at interface Z shall be used.

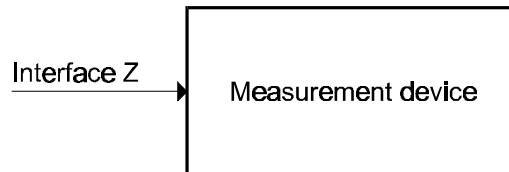

Figure B.1: Test set-up for system availability

### B.2 Link availability

See subclause 6.2.

This measurement monitors the performance of an individual link. Therefore the RS information shall be created and be correct at the start point of the link. The measurement set-up may rely on the overload information coming from the RS decoder in the receiver at interface X or on the `transport_error_indicator` in the header of the TS packets at interface Z.

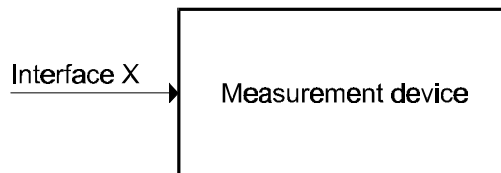

Figure B.2: Test set-up for link availability

### B.3 BER before RS

See subclause 6.3.

The measurement can be done as out service measurement or as in service measurement. In both cases the measurement time is an important parameter. This parameter should be selectable within a wide range by the user. Preferably the measurement should display the BER as a function of measurement time.

#### B.3.1 Out of service measurement

See subclause 6.3.1.

When the BER is measured out of service Null packets as defined in clause A.2 shall be created and transmitted to the receiving site. At the receiving site the signal at the interface W is compared against the pre-calculated values. The time window for the BER measurement should be selectable by the user.

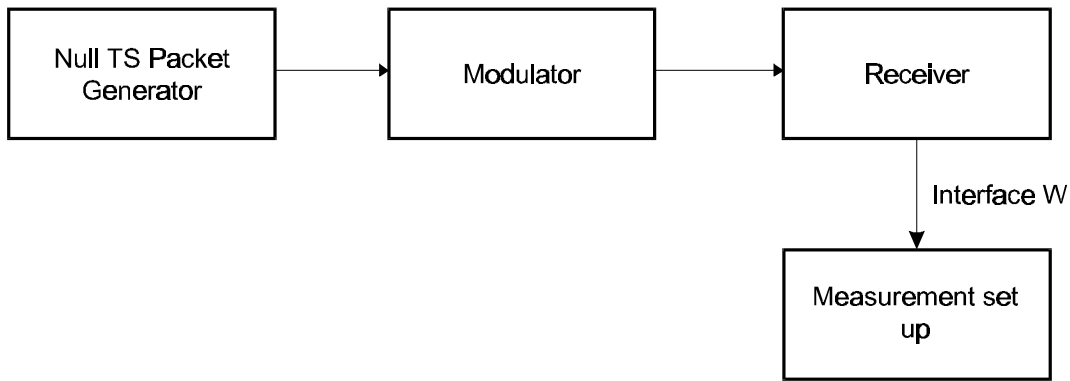
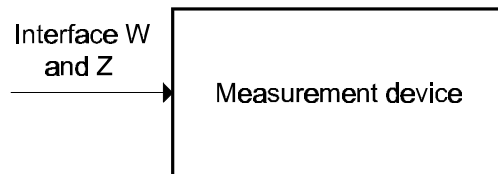

**Figure B.3: Test set-up for out of service BER measurement before RS decoding**

### B.3.2 In service measurement

See subclause 6.3.2.

In this case no special signal shall be inserted in the transmitter. The measurement only relies on the results of the RS decoder. The measurement can be done by using the signals at the interfaces W and Z.

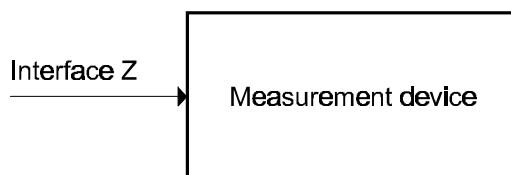

**Figure B.4: Test set-up for out of service BER measurement before RS decoding**

### B.4 Event error logging

See subclause 6.4.

This measurement relies on information coming from different parts of the receiver like tuner, RS decoder or a demultiplexer. Typically the receiver will be a part of the measurement device because it is not expected that all this information will be available at a standard receiver.

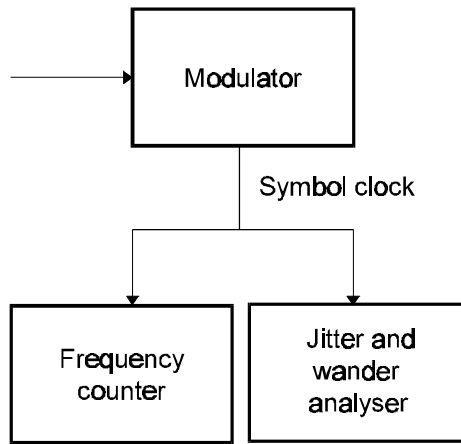

**Figure B.5: Test set-up for event error logging**

### B.5 Transmitter symbol clock jitter and accuracy

See subclause 6.5.

This measurement requires a symbol clock output at the modulator. To this interface an appropriate frequency counter and/or jitter and wander analyser can be connected.



**Figure B.6: Test set-up for transmitter symbol clock measurement**

## B.6 RF/IF signal power

See subclause 6.6.

The signal power can be measured directly at the interfaces N or P or by using a calibrated splitter. If needed an appropriate filter should be used.



**Figure B.7: Test set-up for RF/IF level measurement**

## B.7 Noise power

See subclause 6.7.

Typically all the power present in a channel which is not part of the signal can be regarded as unwanted noise. It can be produced from different origination and be of the form of random noise (thermal), pseudo-random (digitally modulated interfering carriers) or periodic (Continuous Waves CW or narrowband interferences), the first two are called non-coherent and the periodic ones are termed as coherent.

### B.7.1 Out of service measurement

For doing this measurement the carrier shall be switched off. The measurements can be done at interface N (RF level) or at interface P (IF level). Noise level can be measured with a spectrum analyser or any other appropriate device. If a power metre is used the equivalent noise bandwidth should be taken into account. In this case of out-of-service measurement, all different types of noise are measured simultaneously, and the measured result can be termed as unwanted power.



**Figure B.8: Test set-up or out-of-service noise level measurement**

### B.7.2 In service measurement

For the "in service measurement" eye diagrams or IQ constellation diagram derived from I and Q signals available at interface T shall be employed. In this case of "in service measurement", it is possible to determine the type of the noise by applying the I/Q signal analysis (see subclause 6.9).

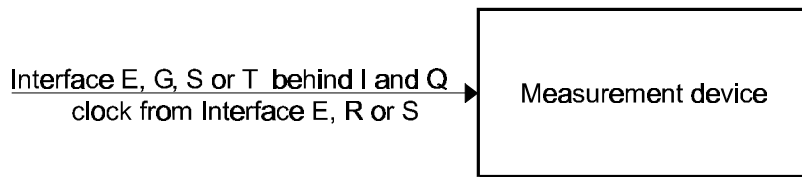

Figure B.9: Test set-up for in service noise level measurement

### B.8 BER after RS

See subclause 6.8.

The set-up is equivalent to subclause 6.3 BER before RS. The comparison is done after RS at interface Y.

### B.9 I/Q signal analysis

See subclause 6.9.

For this measurement eye diagrams or IQ constellation diagram derived from I and Q signals available at interface T shall be employed.

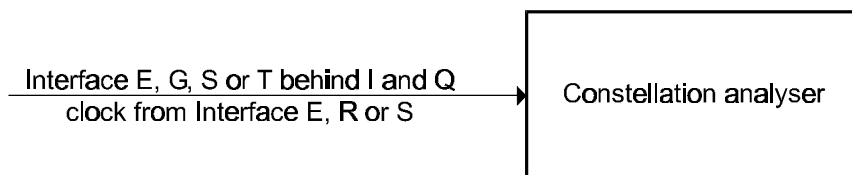

Figure B.10: Test set-up for I/Q signal analysis

### B.10 Service data rate measurement

The set-up is equivalent to B.1 The measurement is based on the TS only.

### B.11 Noise margin

See subclause 7.1.

**Purpose** To provide an indication of the reliability of the transmission channel (i.e. cable network), the noise margin measurement is a more useful measure of system operating margin than a direct BER measurement due to the steepness of the BER curve.

**Interface** The reference interface for the noise injection is the RF interface (N, input of receiver). For practical implementation, other interfaces can be used, provided equivalence to the described set-up is ensured.

**Test set-up** Figure B.11 shows the recommended test **set-up** for the measurement of noise margin.

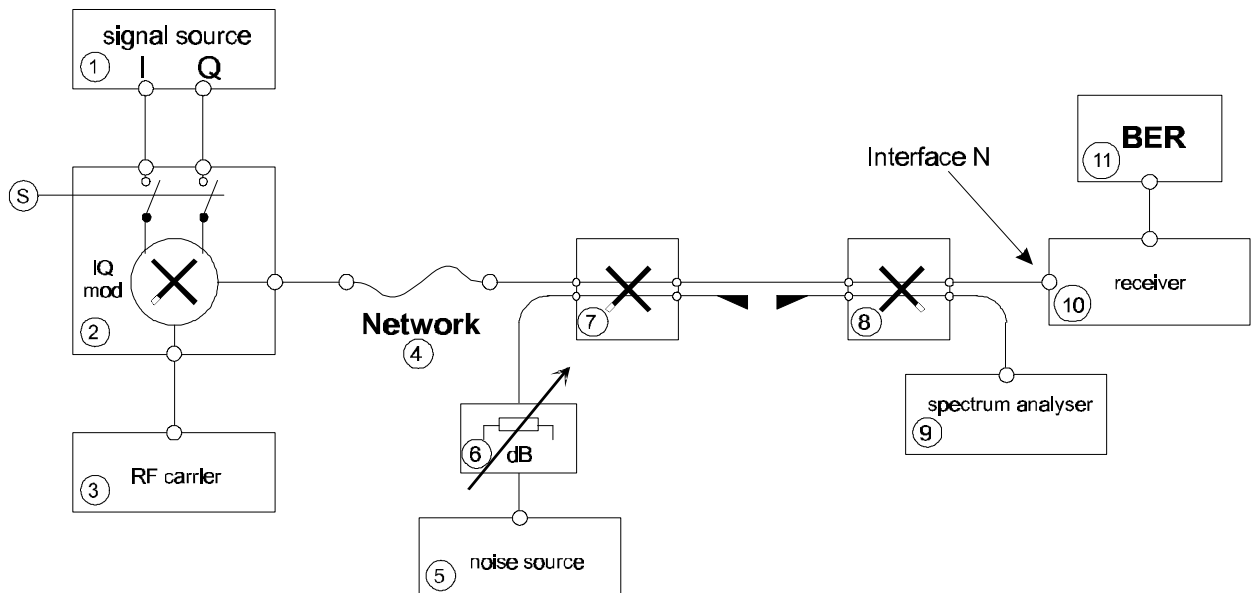

**Figure B.11: Test Set-up for noise margin measurement**

### B.11.1 Recommended equipment

- 1 I/Q baseband signal source for 64 QAM;
- S switch (to switch off modulation);
- 2 I/Q modulator;
- 3 RF generator (see subclause B.11.2 below, remark 1) (level and frequency adjustable);
- 4 cable network (see subclause B.11.2, remark 2);
- 5 noise source (flat within the required measurement range)(see subclause B.11.2, remark 3);
- 6 adjustable attenuator in 0,1 dB (max. 0,5 dB) steps;
- 7, 8 directive couplers (see subclause B.11.2, remark 4);
- 9 spectrum analyser;
- 10 reference receiver with good equalizer (see subclause B.11.2, remark 5);
- 11 counter of BER.

### B.11.2 Remarks and precautions

- 1) Adjust RF carrier level so that non-linear distortion (i.e. CW, CSO, CTB) has no impact to BER measurement.
- 2) Pay attention to the amplitude response of the noise spectrum. If it is not white Gaussian spectrum (flat amplitude response) Figure B.12 take care to measure:
  - a) If the effect produced by the thermal random noise is the wanted measurement, then take the measurement at the lowest level found in the wanted band (P4 in Figure B.12), because it is the closest approximation to the random white thermal noise, then normalize the result to the full bandwidth of the channel, defined by the symbol rate  $x(1 + \alpha)$ .
  - b) If the mean unwanted power is to be reported in the measurement, then integrate the spectrum with a suitable spectrum analyser or use a power metre with the appropriate filter as per subclause B.7.1.

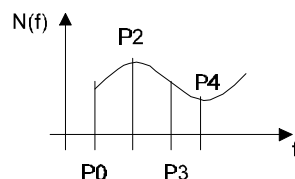

**Figure B.12: Amplitude response of the noise spectrum**

- 3) If a noise source with broadband output spectrum is used, avoid any affect to BER measurement by non-linear distortion due to an overload of the reference receiver's input amplifier stage.
- 4) Usual power splitters are allowed if sufficient matching at all ports is ensured for all measurement conditions (i.e. high attenuation in adjustable attenuator).
- 5) Influence of linear distortion of the cable network to the BER measurement should be negligible.

### B.11.3 Measurement procedure

Step 1: Add noise to modulated cable network output until BER is  $10^{-4}$ .

Step 2: Switch off modulation with (S);

Measure Noise power N1 (dBm) beside carrier ( $\Delta f \geq 0,5$  MHz).

Step 3: Switch off noise source (5);

Measure Noise power N2 (dBm) beside carrier.

Step 4: Compute Noise Margin (NM):

$$NM = N1 - N2 \text{ (dB)}$$

NOTE: Due to step 2, the measurement of noise margin is to be done under out of service conditions.

### B.12 Equivalent Noise Degradation (END)

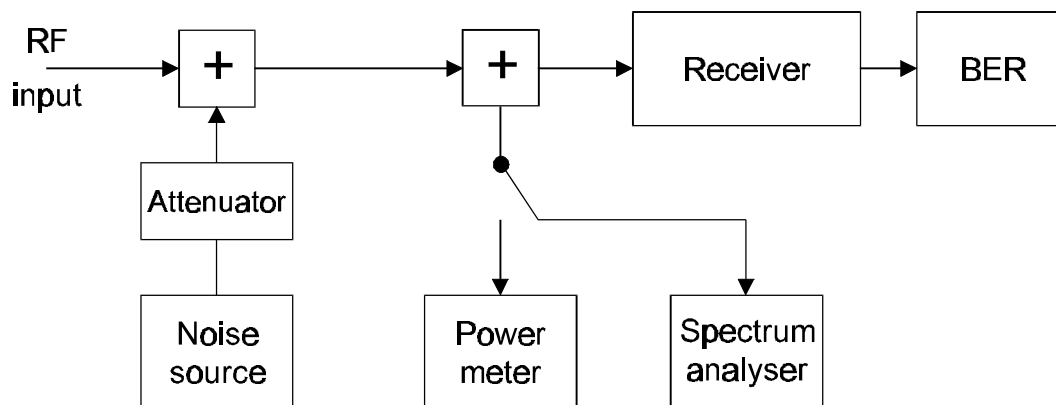

Figure B.13: Test set-up for END measurement

Procedure for the measurement of one point in the diagram:

- 1) Measure the power of the DVB signal with a power metre. If this is not possible due to signals in the neighbouring channels, use a calibrated spectrum analyser.
- 2) Remove the wanted input signal and terminate the input.
- 3) Add noise to obtain the same level on the spectrum analyser. Now C/N = 0 dB.
- 4) Add the wanted input signal and increase the attenuation of the noise until a BER of  $10^{-4}$  is measured. The value, for which the attenuation was increased, is the C/N for the given BER.
- 5) END is the difference between the measured C/N and the theoretical value of C/N for a BER of  $10^{-4}$ .

Proposed settings for the spectrum analyser: RBW = 30 kHz, VBW < 300 Hz.

### B.13 BER vs. $E_b/N_0$

The BER versus  $E_b/N_0$  will be measured using the test set-up described above.

C/N measurements can be converted to  $E_b/N_0$  using the following formula:

$$E_b / N_0 = C/N - 10 \log_{10} (m)$$

### B.14 Equalizer specification

High order modulations such as 64 QAM are very sensitive to distortions. The eye aperture is so small that any perturbation can seriously disturb the reception of the signal. In the case of the DVB modulation formats, this problem is increased by the low value of the roll-off factor (0,15). In a real network, if no special processing is carried out in the receiver, the eyes appear completely closed, and no synchronization is possible. This is why all cable receivers, professional or not, are equipped with equalizers.

Some of the most common impairments met on cable networks are echoes due to equipment impedance mismatching, or filtering effects. These impairments appear as perturbations of the frequency response (or impulse response) of the channel, and are corrected by the equalizer which is a form of adaptive filter. Equalizers are very efficient for linear distortions, but cannot combat those of a non-linear nature. They combat fixed frequency interference, which is equivalent to intermodulation products of analogue television signals. Equalizers have a large influence on the clock or carrier recovery systems, since these can use equalized signals. Thus the overall behaviour of the receiver depends on the performance of the equalizer.

Most of the measurements specified in the present document are carried out after equalization. The first reason is that the signal is too impaired before equalization to obtain meaningful measurement results. Moreover, as most of the distortion at that point would be removed in any practical receiver, such measurements may not be relevant. The consequence of this is that measurement results are dependant on the equalizer response. This also means that equipment with different equalizer architectures will have different performance characteristics. This situation is not acceptable, and has led to the specification of the equalizer.

The specification of an equalizer is a difficult task, because there is a large number of types of equalizer, due to the range of algorithms for the updating of coefficients, and the different filter architectures (time based, frequency based, recursive or non-recursive). In addition, the performance of future equipment should not be limited by any specification here. This is why a convenient solution is to specify the overall performance of the receiver as regards a perturbation typically corrected by the equalizer, specifically - echoes.

The specification has to be defined so that the reference perturbation does not affect the measurement. We will then define the minimum level of perturbation that the equalizer will have to correct. A solution is to set the minimum level of an echo that will not degrade the equivalent noise degradation of the incoming signal of more than 1 dB. This measurement is carried out for the worst case phase shift of the echo.

Figure B.14 gives a possible equalizer specification which is subject to verifications in real systems.

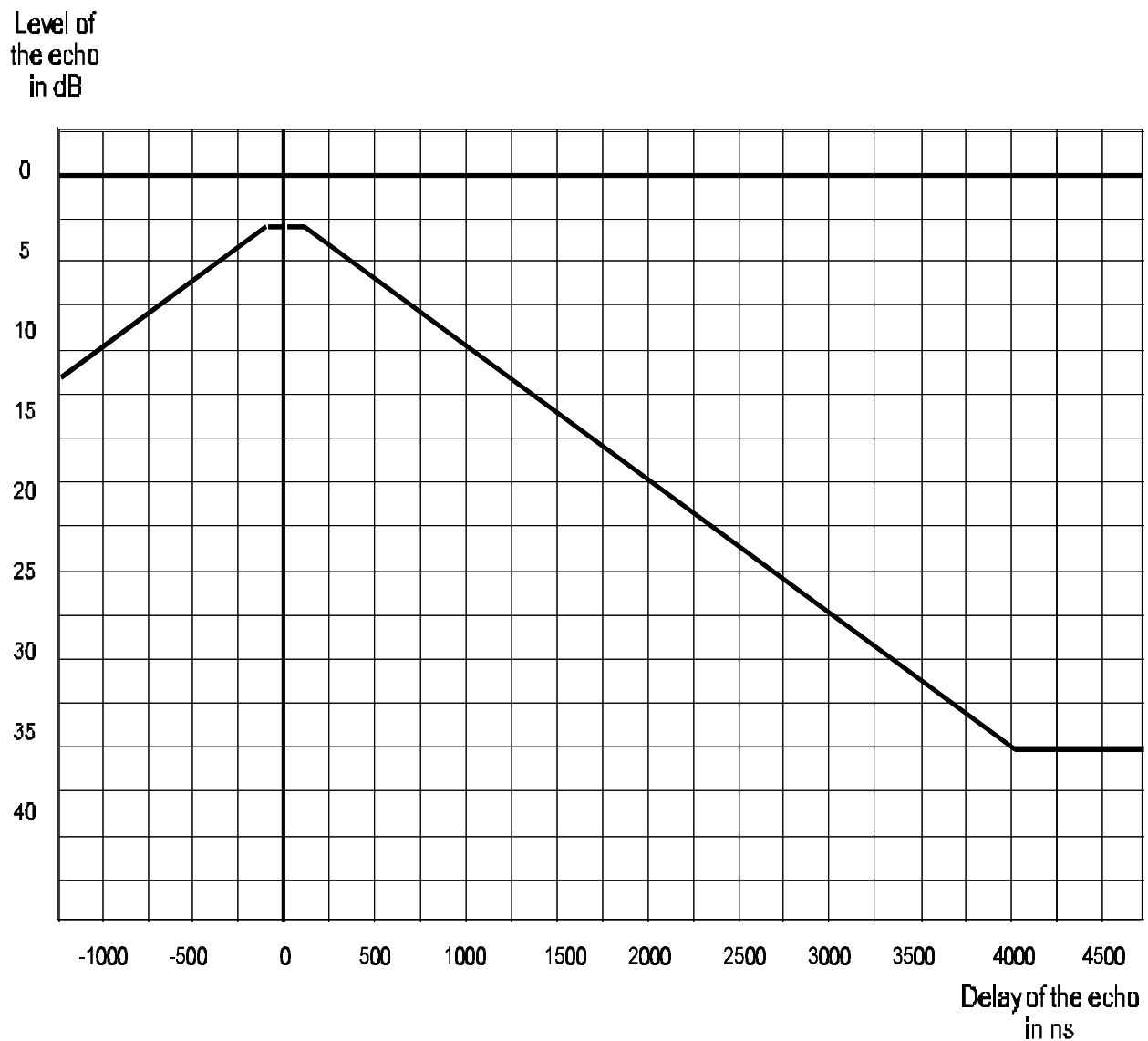

**Figure B.14: Specification of an equalizer**

In some cases, when the likely response of a consumer receiver to network signals is studied, it is appropriate to have an equalizer in the measurement equipment whose performance is close to that of the consumer receiver.

### **B.15 BER before Viterbi decoding**

This measurement shall be based on the I and Q signals at interface T. If an external measurement device is used the signals at interfaces T and V are needed. The set-up is equivalent to Figure B.9.

## B.16 Receive BER vs. $E_b/N_0$

The measurement is based on transmission of Null packets as defined in A.2. At the receiving site noise is added at one of the interfaces N, P or R. The spectrum analyser is used for checking that the normal noise level is well below the added noise. The measurement itself is done either within the receiver or at one of the interfaces T, V or Y depending whether BER before Viterbi, after Viterbi or after RS shall be evaluated. In case of interface Y, RS decoding should be deactivated in order to reduce the duration of the measurement.

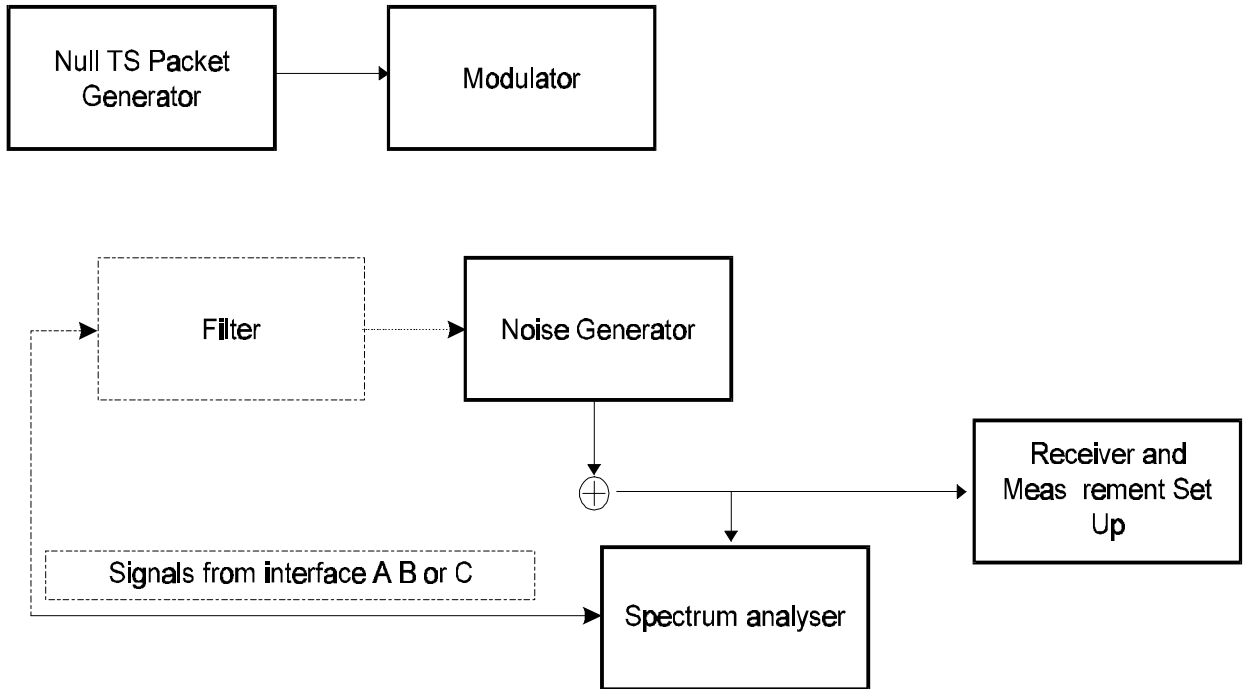

Figure B.15: Test set-up for BER vs.  $E_b/N_0$  measurement

## B.17 IF spectrum

The output of the modulator shall be directly connected to the spectrum analyser. In addition it is also possible to use a (calibrated) splitter.

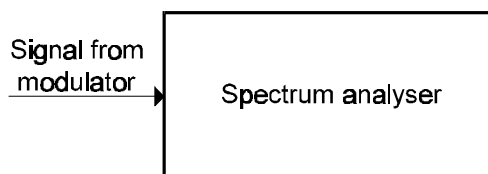

Figure B.16: Test set-up for IF spectrum measurement

## Annex C: Measurement parameter definition

### C.1 Definition of Vector Error Measures

Modulation Error Ratio (MER) is defined as:

$$MER = 10 \times \log_{10} \left\{ \frac{\sum_{j=1}^N (I_j^2 + Q_j^2)}{\sum_{j=1}^N (\delta I_j^2 + \delta Q_j^2)} \right\} dB = 20 \times \log_{10} \left\{ \frac{\sqrt{\sum_{j=1}^N (I_j^2 + Q_j^2)}}{\sqrt{\sum_{j=1}^N (\delta I_j^2 + \delta Q_j^2)}} \right\} dB$$

Error Vector Magnitude (EVM) is defined as:

$$EVM_{RMS} = \sqrt{\frac{\frac{1}{N} \sum_{j=1}^N (\delta I_j^2 + \delta Q_j^2)}{S_{\max}^2}} \times 100\%$$

Where  $I$  and  $Q$  are the ideal co-ordinates,  $\delta I$  and  $\delta Q$  are the errors in the received data points.  $N$  is the number of data points in the measurement sample.  $S_{\max}$  is the magnitude of the vector to the outermost state of the constellation.

### C.2 Comparison between MER and EVM

To compare the two measures it is easier to write them both as simple ratios, clearly the use of decibels and percentages is not central to the definition. Taking MER first, the simple voltage ratio ( $MER_V$ ) is:

$$MER_V = \left\{ \frac{\sqrt{\sum_{j=1}^N (I_j^2 + Q_j^2)}}{\sqrt{\sum_{j=1}^N (\delta I_j^2 + \delta Q_j^2)}} \right\}$$

and multiplying both numerator and denominator by  $\sqrt{1/N}$  gives:

$$MER_V = \left\{ \frac{\sqrt{\frac{1}{N} \sum_{j=1}^N (I_j^2 + Q_j^2)}}{\sqrt{\frac{1}{N} \sum_{j=1}^N (\delta I_j^2 + \delta Q_j^2)}} \right\}$$

Now looking at EVM as a simple voltage ratio ( $EVM_V$ ), we can write:

$$EVM_V = \frac{\sqrt{\frac{1}{N} \sum_{j=1}^N (\delta I_j^2 + \delta Q_j^2)}}{S_{\max}}$$

EVM and MER are related such that:

$$MER_V \times EVM_V = \frac{\sqrt{\frac{1}{N} \sum_{j=1}^N (I_j^2 + Q_j^2)}}{S_{\max}} = \frac{1}{V} = S_{rms} / S_{\max}$$

or

$$EVM_V = \frac{1}{MER_V \times V}$$

If the peak to mean voltage ratio, V, is calculated over a large number of symbols (10 times the number of points in the constellation is adequate if the modulation is random) and each symbol has the same probability of occurrence then it is a constant for a given transmission system. The value tends to a limit which can be calculated by considering the peak to mean of all the constellation points. Table A.2 lists the peak- to-mean voltage ratios for the DVB constellation sizes.

**Table C.1: Peak-to-mean ratios for the DVB constellation sizes**

QAM format	Peak-to-mean voltage ratio (V)
16	1 341
32	1 303
64	1 527

### C.3 Conclusions regarding MER and EVM

MER and EVM measure essentially the same quantity and easy conversion is possible between the two measures if the constellation is known. When expressed as simple voltage ratios  $MER_V$  is equal to the reciprocal of the product of  $EVM_V$  and the peak-to-mean voltage ratio for the constellation.

MER is the preferred measurement for the following reasons:

- The sensitivity of the measurement, the typical magnitude of measured values, and the units of measurement combine to give MER an immediate familiarity for those who have previous experience of C/N or SNR measurement.
- MER can be regarded as a form of Signal-to-Noise ratio measurement that will give an accurate indication of a receiver's ability to demodulate the signal, because it includes, not just Gaussian noise, but all other uncorrectable impairments of the received constellation as well.
- If the only significant impairment present in the signal is Gaussian noise then MER and SNR are equivalent.

## Annex D: Exact values of BER vs. $E_b/N_0$ for DVB-C systems

Exact values of BER vs.  $E_b/N_0$  for DVB-C systems (see Figure 10).

Table D.1: Exact values of BER vs.  $E_b/N_0$  for DVB-C systems

$E_b/N_0$	$P_b$
10	0,02548
10,5	0,02072
11	0,01646
11,5	0,01274
12	0,009582
12,5	0,006981
13	0,004909
13,5	0,003319
14	0,002147
14,5	0,001323
15	0,0007716
15,5	0,0004235
16	0,0002171
16,5	0,0001031
17	4,499e-005
17,5	1,783e-005
18	6,351e-006
18,5	2,006e-006
19	5,537e-007
19,5	1,314e-007
20	2,634e-008
20,5	4,365e-009
21	5,846e-010
21,5	6,166e-011
22	4,974e-012

This assumes that the relationship between BER and Symbol Error Rate (SER) is given by the formula:

$$BER = \frac{1}{m} \times SER$$

## Annex E: Examples for the terrestrial system test set-up

Due to the essential differences in the modulation method used for the terrestrial system some of the test methods are also different with respect to those used for cable and/or satellite.

Even if not demonstrated in the diagrams of this clause and also not mentioned in the explanations, the receiver may be a part of the measurement device. In this case all the interfaces defined in Figure 13 are internal ones, which the measurement device has access to.

### E.1 RF accuracy

See subclause 9.1.

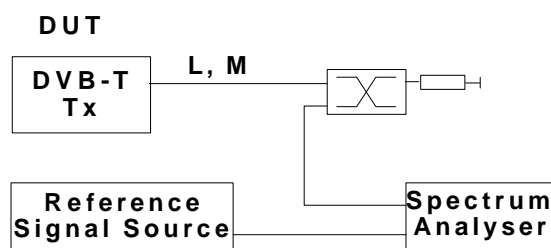

Figure E.1: RF accuracy

The measurement is to be done with a spectrum analyser. The signal can be picked up at interface L (IF) or M (RF), eventually by means of an aerial, or at interface N, if the received signal can be maintained stable enough for the measurement purposes, and applied to a spectrum analyser. Care should be taken at interfaces L or M not to overdrive the maximum allowed input signal for the spectrum analyser.

The central frequency setting of the spectrum analyser should be set to either of the outermost carriers ( $f_L$  or  $f_R$ ) of the spectrum, which correspond to continuous pilot carriers, in order to measure their frequency value. The resolution bandwidth should be set as narrow as necessary to obtain a stable reading of the frequency (at least 1 kHz for the 2 k system or 300 Hz for the 8 k system) and the counting facility of the spectrum analyser activated.

The centre frequency of the spectrum can be calculated as:

$$f_C = (f_L + f_R) / 2$$

NOTE: Most modern spectrum analysers have counting capabilities and frequency stability good enough for the required accuracy expected from the frequency planning authorities, should it not be enough, then an external reference should be used.

### E.2 Selectivity

See subclause 9.2.

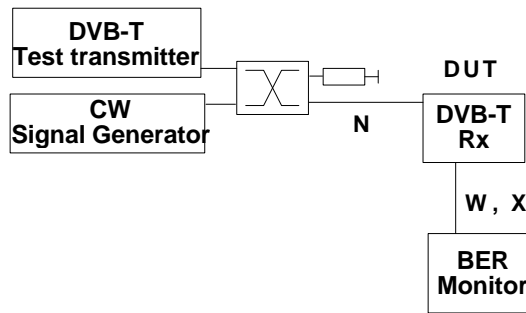

Figure E.2: Selectivity

### E.3 AFC capture range

See subclause 9.3.

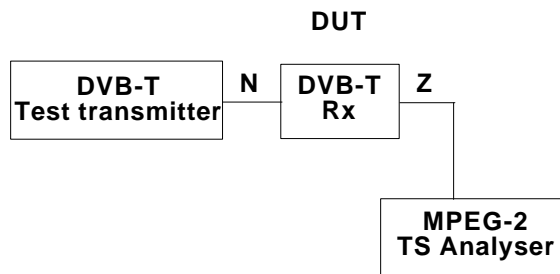

Figure E.3: AFC capture range

### E.4 Phase noise of Local Oscillators (LO)

See subclause 9.4.

The measurement can be done with a spectrum analyser. As the spectrum shape of the phase noise sidebands of any Local Oscillator (LO) used in the process of up/down conversion could be very different depending of factors such as the type of crystal cut, the filter of the PLL, the noise of the active devices involved, etc. it is not convenient to integrate the spectrum of a sideband to reflect a single measured number which could not have meaning at all.

However, samples at certain offsets of the oscillator signal could have more meaning, as indicated in subclause 9.5. In each case of Common Phase Error (CPE) and Inter-Carrier Interference (ICI), 3 frequencies at each side of the oscillator signal should be measured. In order to make the measurement as punctual in frequency as possible, the spectrum analyser should be set to the minimum resolution filter available, and should be, at least, as low as 1 kHz for the 2 k system and 300 Hz for the 8 k system. In order to average the noise, the video filter should be activated with a value of at least 100 times narrower than the resolution filter used. The measured values should be normalized to a 1 Hz bandwidth.

Should the spectrum analyser used not have the 1 Hz normalization capability, it can be done manually with the following criterion:

- For example: carrier frequency: 36 MHz
- $f_m = 10$  kHz (represents any of the required offsets  $f_a$ ,  $f_b$  or  $f_c$ )
- $\Delta B =$  Equivalent Noise Bandwidth (ENB) of the resolution bandwidth filter: 270 Hz
- video bandwidth: 10 Hz or 30 Hz

NOTE 1: The spectrum analysers typically use near Gaussian filters for the resolution bandwidth with a 20 % tolerance. The Equivalent Noise Bandwidth (ENB) is equal to the bandwidth of the filter measured at -3,4 dB, (by actually measuring the filter of the spectrum analyser, the 20 % tolerance factor is eliminated).

Then the following conversion to 1 Hz bandwidth can be applied:

$$P_n \cong (\text{noise\_power\_in\_DB})\text{dBm} - 10\log_{10} \text{DB} + 2,5\text{dB} \quad \text{in [dBm/Hz]}$$

NOTE 2: The 2,5 term accounts for the correction of 1,05 dB due to narrowband envelope detection and the 1,45 dB due to the logarithmic amplifier.

## E.5 RF/IF signal power

See subclause 9.5.

The signal power can be measured directly at the interfaces K, L, M, N or P or by using a calibrated splitter. Care should be taken at interfaces L or M not to overdrive the maximum allowed input signal for the spectrum analyser or power metre.

The shoulders of the spectrum should not be accounted for in the measurement of power because they do not represent any useful power conveying information. The shoulders are unwanted results of the FFT process and also due mainly to non-linearity of the practical implementations.

### E.5.1 Procedure 1 (power metre)

An spectrum analyser is used with an integrating routine which can measure the mean power along frequency slots covering the overall part of the spectrum to be measured (this capability is currently available in several spectrum analyser on the market). In this case the values to be supplied to such a routine or to be used if manual undertaken of the measurement is wanted are:

1. Centre frequency of the spectrum: if possible as calculated under measurement E.2;
2. Spectrum bandwidth of the signal: 7,61 MHz for an 8 MHz channel system.

### E.5.2 Procedure 2 (spectrum analyser)

With the above considerations in mind, it would be very difficult to use an exact square filter for the measurement with a power sensor, however a good approximation should be obtained if a filter is used which can even take in account part of the shoulders in the measurement.

For measuring with a thermal power sensor such an appropriate filter should be used.



Figure E.4: Test set-up for RF/IF power measurement

## E.6 Noise power

See subclause 9.6.

Typically all the power present in a channel which is not part of the signal can be regarded as unwanted noise. It can be produced from different origination and be of the form of random noise (thermal), pseudo-random (digitally modulated interfering carriers) or periodic (Continuous Waves CW or narrowband interference), the first two are called non-coherent and the periodic ones are termed as

coherent. In this measurement, all different types of noise are measured simultaneously, and the measured result can be termed as unwanted power.

For doing this measurement the signal shall be switched off. The measurements can be done at interface N (RF level) or at interface P (IF level).

Noise level can be measured with a spectrum analyser or any other appropriate device. The same bandwidth considerations and methodology used in clause E.6 apply to this measurement in both cases, using a power metre and a spectrum analyser.



**Figure E.5: Test set-up for out-of-service noise power measurement**

**E.6.1 Procedure 1**

Exactly equal to the above preferred procedure for signal power, clause E.6, but understanding that the signal for this channel under measurement has been switched off.

**E.6.2 Procedure 2**

Using a power metre as in the alternate procedure above in clause E.6, using the same filter and with the channel signal off.

**E.6.3 Procedure 3**

If the noise floor in all bandwidth of interest is flat, it would be possible to measure the noise power at any frequency point inside the channel bandwidth and normalize the value to the nominal bandwidth of  $(n-1) \times f_{\text{SPACING}}$  (7,61 MHz for 8 MHz channels 6,66 MHz for 7 MHz channels).

If the spectrum analyser does not have normalization routine to the wanted bandwidth the following procedure can be used.

In order to average the noise, the video filter should be activated with a value of at least 100 times narrower than the resolution filter used, this resolution bandwidth filter should be chosen to be as wide as possible in order to average as much spectrum of the channel as possible, but not exceeding such bandwidth (e.g. 7,61 MHz), the equivalent noise bandwidth  $\Delta B$  (MHz) of the filter should be known by the specifications given by the manufacturer, or measured following manufacturer indications. The noise power measured can be normalized to the wanted bandwidth using the following formulae:

$$\text{Noise power (dB)} = \text{Measured level (dB)} + 10 \log_{10} (7,61/\Delta B) + 2,5 \text{ dB} \quad (\text{for 8 MHz channels})$$

If the spectrum analyser has a routine to normalize to 1 Hz, (this use to include the 2,5 dB correction) but not able to normalize to the wanted bandwidth, the following conversion can be applied:

$$\begin{aligned} \text{Noise power (dB)} &= \text{Measured level (dB/Hz)} + 10 \log_{10} (7,61 \times 10^6) = \\ &\text{Measured level (dB/Hz)} + 68,8 \text{ dB} \quad (\text{for 8 MHz channels}) \end{aligned}$$

**E.6.4 Measurement of noise with a spectrum analyser**

Care should be taken when the measured noise has a display level close to the display level of instrument noise, (less than 10 dB), because an additional proximity factor should be applied. This is typically done automatically in some instruments available in the market.

If this is not available in the instrument, it is necessary to subtract a correction factor CF from the noise level measured, the following correction table can be used:

**Table E.1: Correction Factor (CF) for measured noise level**

D (dB)	CF (dB)
0,5	8,63
1	6,87
1,5	5,35
2	4,33
3,01	3,01
4	2,2
5	1,65
6	1,26
7	0,98
8	0,75
9	0,58
10	0,46

D is the distance in display level between the instrument noise (no signal applied to the input) and measured noise level (with no change in the settings).

Notice that below 2 dB of D, the reliability of the result after applying the CF is under question due to the uncertainty of the measurement and the corresponding big value of CF to be subtracted.

## E.7 RF and IF spectrum

See subclause 9.7.

To be defined after some practical experience is achieved.

## E.8 Receiver sensitivity/dynamic range for a Gaussian channel

See subclause 9.8.

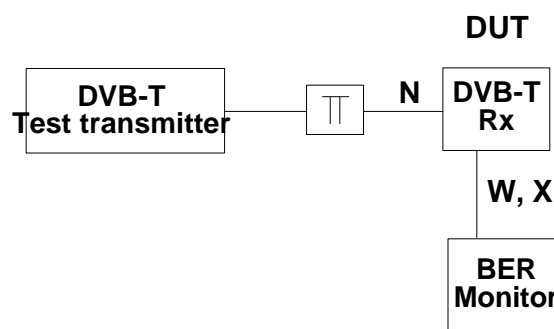

**Figure E.6: Receiver sensitivity/dynamic range for a Gaussian channel**

## E.9 Equivalent Noise Degradation (END)

See subclause 9.9.

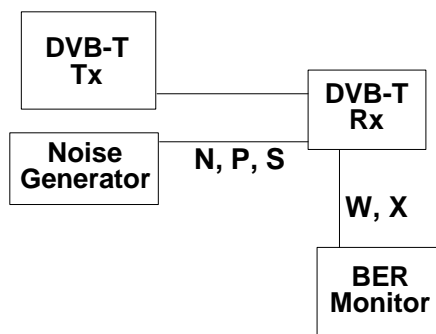

Figure E.7: Equivalent Noise Degradation (END)

## E.10 Linearity characterization (shoulder attenuation)

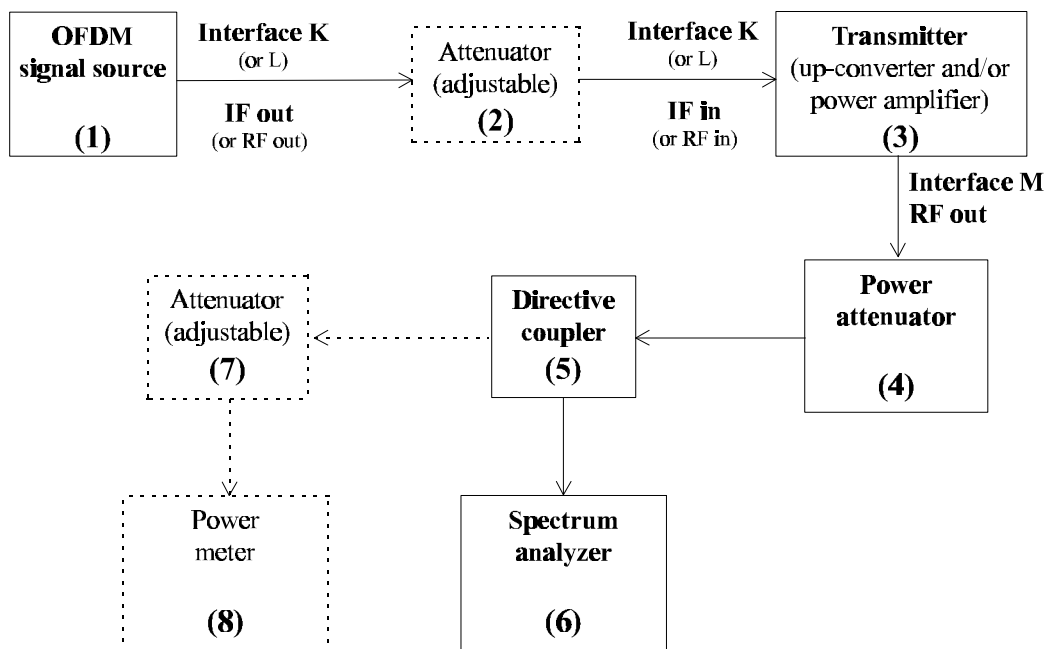

Figure E.8: Test set-up for "linearity characterization"

### E.10.1 Equipment

- (1) OFDM signal source (interface K or L of DVB-T transmitter);
- (2) attenuator, possibly adjustable in 0,1 dB (max. 0,5 dB) steps. Optional, see subclause E.10.2, remark (d);
- (3) transmitter under measurement;
- (4) power attenuator;
- (5) directive coupler or attenuator, see subclause E.10.2, remark (a);
- (6) spectrum analyser;
- (7) attenuator, possibly adjustable. optional, see subclause E.10.2, remark (c);
- (8) power metre. optional, see subclause E.10.2, remark (a).

### E.10.2 Remarks and precautions

- (a) Power metre (8) can be useful to verify and monitoring the output power of the transmitter (3) and for the calibration process. If power metre (8) is not available, the directive coupler (5) can be replaced by an opportune attenuator connected to the spectrum analyser (6).
- (b) Care should be taken in the choice of the power attenuator (4) in terms of max. admitted power.
- (c) Care should be taken in the choice of all attenuators (and directive coupler) to prevent damage to test-set equipment. For example, the function of the optional attenuator (7) is to protect the probe of the power metre. The attenuator (7) can also be useful for other measurements and, for example, be connected in a chain to the receiver.
- (d) Pay attention to the admitted power at the IF (or RF) input of the transmitter, in order to obtain a proper working point. Optional attenuator (2) can be used for this purpose.

### E.10.3 Measurement procedure (example for UHF channel 47)

- Step 1: Select the centre frequency of spectrum analyser in the middle of the UHF channel (i.e. 682 MHz for channel 47). Verify the output power level using an high resolution BW (3 or 5 MHz) and compare with the value obtained by the power metre (if available).
  - Step 2: Select the centre frequency of spectrum analyser at the end of the UHF channel (i.e. 686 MHz for channel 47).
  - Step 3: Select an adequate span (for example 2 MHz).
  - Step 4: Select the resolution BW (10 kHz is adequate for 2 k and 8 k mode) and adjust levels. Video BW is of the same order.
  - Step 5: Measure the power level at 300 kHz and 700 kHz from upper edge of the DVB-T spectrum and proceed as indicated in subclause 9.10. Last DVB-T carrier is at approximately +3,8 MHz from the centre of the UHF channel: then, for channel 47, the two measurement points are at 686,1 MHz and 686,5 MHz.
  - Step 6: Repeat steps from 2 to 5 for the lower edge of the spectrum.
  - Step 7: The worst case value of the upper and lower results is the "shoulder attenuation" (dB).
- NOTE: The value obtained should be joined up with the used mode (2 k or 8 k) of the OFDM source.
- If available, the "maximum-hold" function of the spectrum analyser can help to carry out the measurement.



### E.13 BER vs. C/N by variation of transmitter power

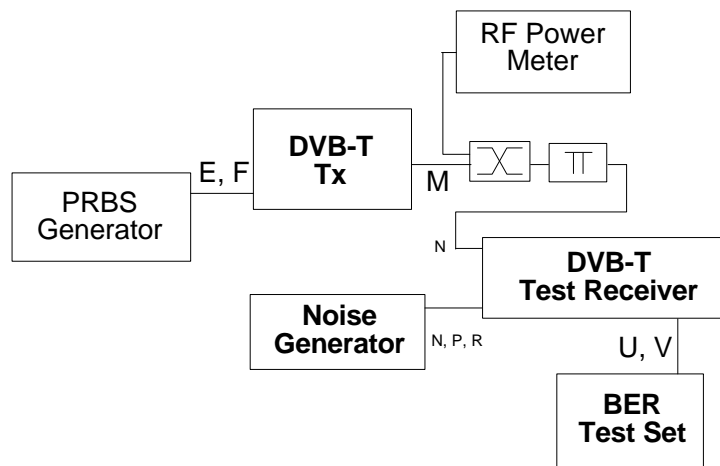

Figure E.11: BER vs. C/N by variation of transmitter power

Adjust signal level at receiver input to the same value for different Tx output power values by attenuator.

The results of this measurement can be put in diagrams, such as:

- BER vs. C/N for constant  $P_{out}$ ;
- BER vs.  $P_{out}$  for constant C/N;
- BER vs.  $P_{out}$  for constant noise power.

### E.14 BER vs. C/N by variation of Gaussian noise power

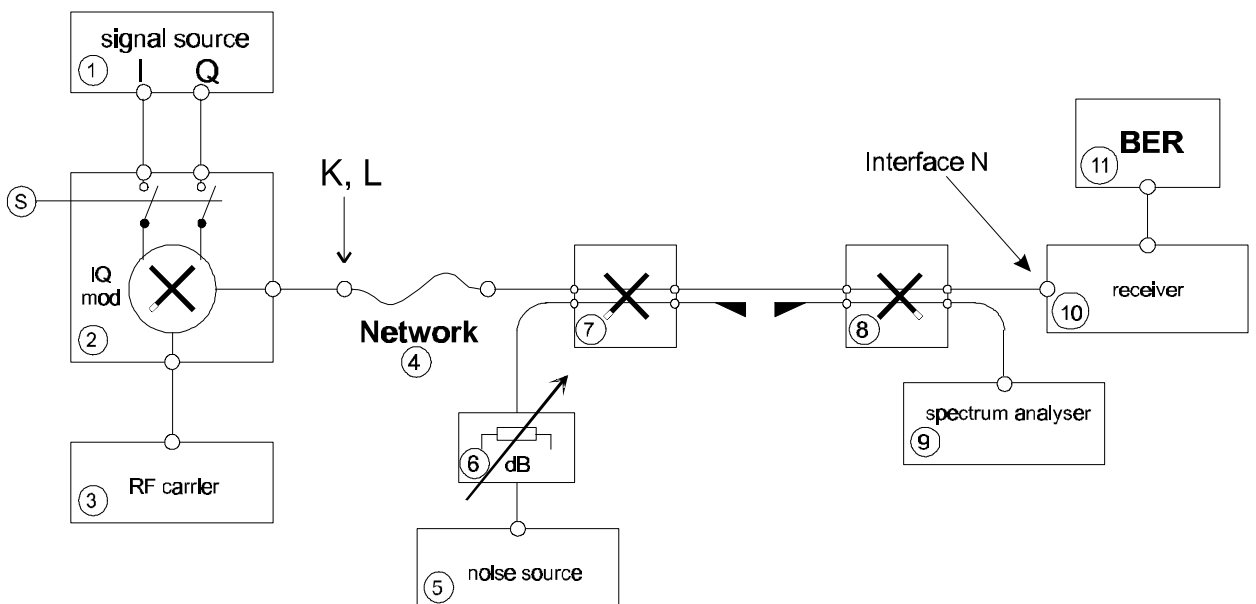

Figure E.12: BER vs. C/N by variation of Gaussian noise power

### E.15 BER before Viterbi (inner) decoder

See subclause 9.15.

NOTE: For the measurements described in subclauses 9.15, 9.16, 9.17, 9.18 and 9.19 dedicated measurement instruments are envisaged.

## Annex F: Specification of test signals of DVB-T modulator

### F.1 Introduction

In order to compare simulated data within a DVB-T modem it is necessary to specify test points, signal formats and a subset of modes. The present document contains the specifications of how to do this. This specification should be accurate enough to enable comparison of simulated data at different points within the modulator.

### F.2 Input signal

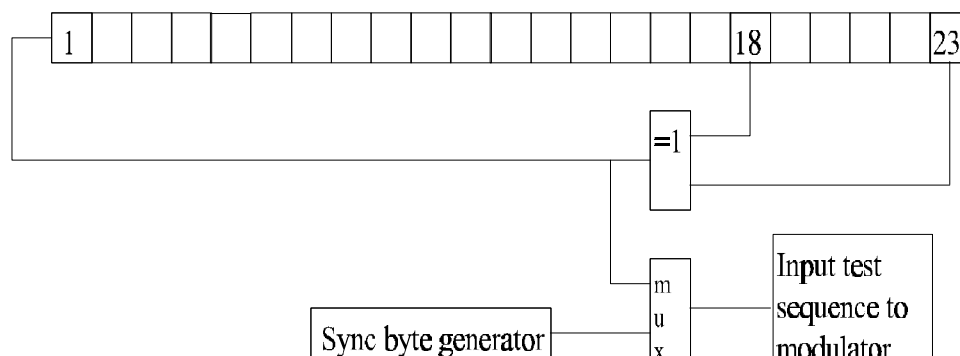

Figure F.1: Input test sequence generator for DVB-T modulator

The number of bits in a super-frame is depending on the actual DVB-T mode. The maximum number of Reed-Solomon/MPEG-2 packets in a super-frame is 5 292. This corresponds to 7 959 168 input bits that is shorter than a maximum length sequence of length  $2^{23}-1 = 8\,388\,607$ . The input test sequence to the modulator can therefore be generated by a shift register of length 23 with suitable feedback. The generator polynomial should be  $1 + x^{18} + x^{23}$ . The PRBS data on every 188 byte is replaced by the sync byte content, 47 HEX. This means that during the sync bytes the PRBS generator should continue, but the source for the output is the sync byte generator instead of the PRBS generator. The input test sequence starts with a sync byte as the first eight bits, and the initialization word in the PRBS generator is "all ones". The PRBS generator is reset at the beginning of each super-frame. The test sequence at the beginning of each super-frame starts with:

0100 0111 0000 0000 0011 1110 0000 0000 0000 1111 1111 1100 (first byte is sync byte 47 HEX).

The corresponding HEX numbers are: 47 00 3E 00 0F FC.

There are up to eight possible phases of the energy dispersal with respect to the start of the super-frame. The first sync byte in the sequence, i.e. the first 8 bits should be inverted by the energy dispersal block. The length of the input signal can in principle be arbitrary. However, it is not meaningful to have a sequence shorter than one OFDM symbol. The maximum length will in practice be limited by the amount of data. Very large data files may be difficult to handle and interchange. One super-frame is therefore regarded as the longest sequence of interest. The outer interleaver will spread data across the super-frame boundaries. **The ambiguity in the output sequence caused by this is circumvented by using the second super-frame in the simulated sequence as the output signal.** This means that the simulator should produce one super-frame before useful data starts to appear at the output.

The file format for storing data allows for variable lengths of simulated data since the length indicator is contained in the header of the file. Simulations with different lengths can therefore be compared over the length of the shortest sequence.

### F.3 Test modes

The file header in the test file contains information about the specific DVB-T mode used for the simulation. By reading this information a complete description of the set-up is obtained. In order to ease comparison of data and to reduce the amount of simulations necessary a set of "preferred modes" are defined. The preferred test mode for non-hierarchical transmission is:

Inner code rate: 2/3;  
Modulation method: 64 QAM;  
FFT size: 8 k;  
Guard interval: 1/32.

For hierarchical transmission the preferred mode is:

Inner code rate HP: 2/3;  
Inner code rate LP: 3/4;  
Modulation method: QPSK in 64 QAM,  $\alpha = 2$ ;  
FFT size: 8 k;  
Guard interval: 1/32.

### F.4 Test points

The simulated data can be probed at different points within the modulator. Eight test points are defined, which are related to the interfaces described in Figure 12:

- 1) at input (A);
- 2) after mux adaptation, energy dispersal (B);
- 3) after outer encoder (C);
- 4) after outer interleaver (D);
- 5) after inner encoder (E);
- 6) after inner interleaver (F);
- 7) after frame adaptation (H);
- 8) after guard interval insertion (J).

### F.5 File format for interchange of simulated data

The file header as well as simulated data from the modem are stored as ASCII characters on files **with carriage return and line feed at the end of each line**. In order to interchange data it is important that the same file format be used by everyone. A file containing such data should have a header which has the following information:

- text string with a maximum of 80 characters (affiliation, time, place etc.);
- "printf" string used to store the data in the data section of the file;
- test point description;
- length of data buffer;
- constellation;
- hierarchy;
- code rate (code rate for HP);
- code rate LP (Don't care for non-hierarchical modes);
- guard interval;
- transmission mode;
- simulated data (HEX or floating point).

The specification for each of these entries are given in the tables F.1 to F.8.

### F.5.1 Test point number

**Table F.1: Test point number**

Test point	Interface	Text contained in file header
1	A	at input
2	B	after MUX adaptation and energy dispersal
3	C	after outer coder
4	D	after outer interleaver
5	E	after inner coder
6	F	after inner interleaver
7	H	after frame adaptation
8	J	after guard interval insertion

### F.5.2 Length of data buffer

The length indicator specifies the number of lines contained in the data section of the file which has two floating points or one two digit HEX on each line.

### F.5.3 Bit ordering after inner interleaver

The signal at test point 4 after inner interleaver should contain data from one carrier on each line. The bit ordering should be according to table F.2.

**Table F.2: Bit ordering in the signal representation at test point 4, after the inner interleaver**

Modulation method	Bit ordering	Representation
QPSK	$y_{0q} y_{1q}$	2-digit HEX (00 to 03)
16 QAM	$y_{0q} y_{1q} y_{2q} y_{3q}$	2-digit HEX (00 to 0F)
64 QAM	$y_{0q} y_{1q} y_{2q} y_{3q} y_{4q} y_{5q}$	2-digit HEX (00 to 3F)

### F.5.4 Carrier allocation

The signal contains 1 705 or 6 817 active carriers for the 2 k and 8 k modes respectively. In order to ease comparison of different data sets the allocation of these into the FFT bins should be specified. The signal is arranged such that it is centred around half the sampling frequency.

**Table F.3: Carrier allocation**

	FFT bins containing zeros	FFT bins containing active	FFT bins containing zeros
2 k mode	0 to 171	172 ( $K_{min}$ ) to 1 876 ( $K_{max}$ )	1 877 to 2 047
8 k mode	0 to 687	688 ( $K_{min}$ ) to 7 504 ( $K_{max}$ )	7 505 to 8 191

### F.5.5 Scaling

At test point 7 (after frame adaptation) the data should be scaled such that: "Vector length of a boosted pilot" is equal to unity.

The gain factor through the IFFT should be equal to unity. This gain factor is defined as:

$$\eta = \sqrt{\frac{\sum_N (z z^*)}{\sum_N (x x^*)}}$$

where x are the complex numbers representing one complete OFDM symbol at the input of the IFFT including data carriers, pilots and null-carriers. And z is the complex signal for the corresponding OFDM symbol at the IFFT output before guard interval insertion. The number N is equal to the IFFT size (2 k or 8 k). The asterisk denotes complex conjugate. This ensures correct scaling of data at test point 8 (after guard interval insertion).

### F.5.6 Constellation

The possible constellations are listed in table F.4. The file header should contain one of them.

**Table F.4: Constellations**

<b>QPSK</b>
16-QAM
64-QAM

### F.5.7 Hierarchy

The hierarchical identifier specifies if hierarchical mode is on or off and also the alpha value in case hierarchical mode is on. For non-hierarchical transmission alpha is set to one. Table F.5 contains the possible choices and the file header should contain one of them.

**Table F.5: Hierarchical identifier**

<b>Non-hierarchical, alpha = 1</b>
Hierarchical, alpha = 1
Hierarchical, alpha = 2
Hierarchical, alpha = 4

### F.5.8 Code rate LP and HP

The code rate identifiers specifies the code rate for the LP and HP streams. Table F.6 contains the possible choices and the file header should contain one of them.

**Table F.6: Code rate identifier**

<b>Code rate identifier</b>
1/2
2/3
3/4
5/6
7/8

### F.5.9 Guard interval

Table F.7 contains the possible choices for the guard interval and the file header should contain one of them.

**Table F.7: Guard interval identifier**

Guard interval identifier
1/32
1/16
1/8
1/4

### F.5.10 Transmission mode

The transmission mode can be either 2 k or 8 k. Table F.8 contains the possible choices and the file header should contain one of them.

**Table F.8: Transmission mode identifier**

Transmission mode identifier
2 048
8 192

### F.5.11 Data format

The data at test point 1 to 6 are written to file using 2-digit HEX numbers with "printf" string %X\n.

At test point 7 and 8 each line in the file contains real and imaginary parts with at least 6 significant decimal digits each. The real and imaginary parts are separated by at least 2 spaces. The data is written to file using "printf" with %e\n.

### F.5.12 Example

This is an example of a print-out of a file containing the data sequence at the input for the preferred mode for non-hierarchical transmission. The text in parenthesis is just for explanation and should not be contained in the file.

Stockholm, May 22, 1996, example of input data. Preferred non-hierarchical mode:

%X\n	(Data stored in HEX format);
at input	(Data at test point 1 at modulator input);
758016	(One super-frame of data);
64-QAM	(Constellation 64 QAM);
non-hierarchical, alpha = 1	(Non hierarchical transmission);
2/3	(2/3 inner code rate);
0	(Don't care. Code rate LP);
1/32	(Guard interval = 1/32);
8 192	(8 k IFFT size);
47	(First data byte is sync byte 47 HEX);
00	(Rest of data).

## Annex G: Specification of test signals of DVB-T modulator

This informative annex presents a review of the theoretical background to the measurement techniques recommended in the present document. It is an attempt to gather the most relevant background information into one location, particularly for the benefit of engineers and technicians who are new to digital modulation techniques. It is hoped that it will provide a working knowledge of the theoretical and practical issues, particularly the potential sources of ambiguity and error, to help users of the present document make valid, accurate and repeatable measurements.

### G.1 Overview

The basic purpose of a digital transmission system is to transfer data from A to B with as few errors as possible. It follows that the fundamental measure of system quality is the transmission error rate.

The transmission error rate is usually measured as the Bit Error Rate (BER), however it can also be informative to consider the error rate of other transmission elements such as bytes, MPEG packets, or m-bit modulation symbols. In practice, although a certain guaranteed minimum BER performance may be a system implementation goal, the system BER alone is not a particularly informative measurement.

The most important figure of merit for any digital transmission system is the BER expressed as a function of the ratio of wanted information power to unwanted interference power (C/N). This is underlined by the fact that most of the measurements in the present document are built around this central theme of BER vs. C/N (or, equivalently, BER vs.  $E_b/N_0$ ).

There are measurements of the individual elements (power and BER measurements). There are measurements of the difference between theoretical and ideal performance (margin and degradation measurements). There are measurements intended to help identify the sources of transmission errors (interference, spectrum, jitter and I/Q measurements). There are measurements for monitoring the consequences of transmission errors at the system level (availability, error event logging).

### G.2 RF/IF power ("carrier")

When describing the Quadrature Amplitude Modulated (QAM) signals employed by DVB-C or the Quadrature Phase Shift Keying (QPSK) signals employed by DVB-S, it is common to refer to the modulated RF/IF signal as "carrier" (C), mainly to distinguish it from "signal" (S) which is generally used to refer to the baseband demodulated signal.

Strictly, it is incorrect to describe this signal as "carrier" because QAM and QPSK (which is equivalent to 4-state QAM) are suppressed carrier modulation schemes. For OFDM, with thousands of suppressed carriers and assorted pilot tones, the label "carrier" is even more inappropriate. This is why deliberately the expression "wanted information power" is used in the paragraph above, and why the parameter is referred to as "RF/IF power" in the present document.

However, it is clear that engineers will continue to use "carrier" as a convenient shorthand for this parameter, particularly when talking about the "carrier"-to-noise ratio. It seems futile to attempt to change this, so instead it is clearly defined what is meant by "carrier" in this context. Carrier, more accurately called RF/IF power, is the total power of the modulated RF/IF signal as would be measured by a thermal power sensor in the absence of any other signals (including noise).

For DVB compliant systems the QAM/QPSK passband spectrum is shaped by root raised cosine filtering with a roll-off factor alpha ( $\alpha$ ) of 0,15 for DVB-C systems, or 0,35 for DVB-S systems. For an ideal QAM/QPSK system this means that all the RF/IF power will lie in the frequency band:

$$BW_{OCC(QAM)} = f_C \pm (1 + \alpha) \times \frac{f_S}{2} \quad (G.1)$$

Equation G.1 defines the **occupied bandwidth** of the signal, where  $f_C$  is the carrier frequency,  $f_S$  is the symbol rate of the modulation, and  $\alpha$  is the filter roll-off factor. RF/IF power (or "carrier") is the total power in this "rectangular" bandwidth, that is, with no further filtering applied.

For OFDM systems the definition of occupied bandwidth is expressed differently because of the radically different modulation technique, however the principle is very similar. The OFDM "shoulders" are not considered to be wanted information power, and are not included in the RF/IF power calculation, even though the power does actually come out of the transmitter:

$$BW_{OCC(OFDM)} = n \times f_{SPACING} \quad (G.2)$$

where  $n = 6\,817$  (8 k mode) or  $1\,705$  (2 k mode) and  $f_{SPACING} = 1\,116$  Hz (8 k mode) or  $4\,464$  Hz (2 k mode).

In a real multi-signal system (e.g. a live CATV network) measurement of the RF/IF power in a single channel requires a frequency selective technique. This could employ a thermal power metre preceded by a suitably calibrated channel filter, a spectrum analyser with band power measurement capability, or a measuring receiver. Depending on the measurement technique a filter may be required to exclude the "shoulders" of a single OFDM signal.

### G.3 Noise level

The noise level is the unwanted interference power present in the system when the wanted information power is removed. This is a less bounded quantity than the RF/IF power because there is no definitively "correct" bandwidth over which to measure the noise. The choice is to some extent arbitrary, but the "top three" choices are probably:

- 1) **Channel bandwidth:** In a channel based system such as a CATV network you could choose the channel bandwidth, for example 8 MHz, as the system noise bandwidth. This is considered by the DVB-MG to be inappropriate for C/N measurements in digital TV systems. It will result in misleadingly poor C/N ratios when the modulation symbol rate is low relative to the available channel bandwidth. It unnecessarily complicates conversion between C/N measurements made "*in the channel*" and "*in the receiver*" by introducing symbol rate dependent correction factors.
- 2) **Symbol rate:** For digital modulation employing Nyquist filtering split equally between the transmitter and receiver, the noise bandwidth of the receiver equals the symbol rate. This is considered by the DVB-MG to be appropriate for "*in the receiver*" C/N measurements of digital TV systems since this reflects the amount of noise entering the receiver independent of symbol rate.
- 3) **The occupied bandwidth:** For digital modulation employing Nyquist filtering the occupied bandwidth of the modulated signal is  $(1 + \alpha) \times f_S$ . This is considered by the DVB-MG to be appropriate for "*in the channel*" C/N measurements of digital TV systems since it exactly covers the transmitted spectrum, independent of symbol rate.

The DVB-MG have chosen **occupied bandwidth**, as defined by equation G.1, as the standard definition of noise bandwidth in DVB-C and DVB-S systems. This is primarily because "*in the channel*" C/N is considered to be the fundamental measurement, but also because a simple correction factor can be applied to determine the equivalent "*in the receiver*" C/N value.

The other possibility that should be mentioned is to assume that the noise power is evenly distributed across the frequency spectrum of interest and so can be described by a single noise power density value ( $N_0$ ) which is the noise power present in a 1 Hz bandwidth. From this, the noise power present in any given system noise power bandwidth ( $BW_{SYS}$ ) can be obtained by simple multiplication:

$$N = N_0 \times BW_{SYS} \quad (G.3)$$

By talking in terms of  $N_0$  we are freed from the need to define a noise bandwidth, but we are making an assumption that the noise power spectrum is flat across the bandwidth of interest.

### G.4 Energy-per-bit ( $E_b$ )

Trying to commission a DVB system against tight deadlines, Energy-per-bit ( $E_b$ ) seems to be a rather academic concept, particularly since the directly measurable quantity is RF power.

However, it is useful to understand  $E_b$ , even if only to avoid confusion when it appears in technical specifications or discussions. Historically, use of  $E_b$  arises from information theory and as part of an academic desire to normalize the performance of different modulation formats and coding schemes for comparative purposes.

The Energy-per-bit is the energy expended in transmitting each single bit of information.  $E_b$  is of little practical use on its own, it is most useful in the context of a graph of BER vs. the  $E_b/N_0$  ratio - the well known "waterfall curve" (see Figures G.1 and G.2).

By normalizing to an  $E_b/N_0$  ratio on the X axis, the relative performance of various complexities of digital modulation and channel coding can be compared because the scaling effects of actual signal and noise powers, number of bits-per-symbol and symbol rate are removed. It is then simply a case of comparing the bit error probability for a given ratio.

Energy-per-bit can be easily translated to carrier power. Power is energy-per-second. Which can be expanded to energy-per-bit, times bits-per-symbol, times symbols-per-second. Expressed algebraically we get:

$$C = E_b \times \log_2(M) \times f_s \quad (G.4)$$

## G.5 C/N ratio and $E_b/N_0$ ratio

The parameters that can be directly measured are RF/IF or "carrier" power (C) and noise power in a certain bandwidth (N). From these measurements we can immediately compute the C/N ratio.

With the equations above, knowledge of the other parameters (e.g.  $f_s$ ) and a little algebra we can also arrive at an equivalent  $E_b/N_0$  ratio.

## G.6 Practical application of the measurements

At this point it seems that C/N (or  $E_b/N_0$ ) is defined, and indeed it is from an algebraic perspective.

However, there is scope for endless confusion in applying these simple formulae unless the user is very clear about where the C/N or  $E_b/N_0$  ratio is being measured, and what values are being used for the subordinate parameters, most particularly the system noise bandwidth.

C/N (or  $E_b/N_0$ ) can be measured "*in the channel*" or "*in the receiver*". The meaning of "*in the channel*" is fairly self-evident, "*in the receiver*" may need further explanation.

There are typically three filtering processes present in a receiver. The first (which is optional) is a relatively broadband tuneable pre-selection simply to reduce the power presented to the receiver RF front-end. The second, usually applied at an IF, is a high-order bandpass channel selection filter to extract the desired signal with (ideally) no modification of the signal spectrum. The third is the root-raised cosine Nyquist filtering, commonly implemented in the low pass filters following the I/Q demodulation.

For theoretical simplicity we assume that the receiver's bandwidth and band shape are defined totally by the low-pass root-raised cosine filters because the intended purpose of the other RF/IF filters is only signal pre-selection. So we can model the receiver as a broadband receiver with a root-raised cosine passband filter followed by I/Q demodulation.

With this in mind, "*in the receiver*" can be seen to mean "*after the bandwidth and band shape modifying effects of the receiver Nyquist filters has been taken into account*".

Whether artificially generating a specific C/N ratio or just measuring the existing C/N ratio it is important to understand the difference between the "*in the channel*" and "*in the receiver*" nodes.

On a more practical note, graphing the BER performance of a receiver versus  $E_b/N_0$  removes the ambiguity introduced by varying noise bandwidth. If we use the "*in the channel*"  $E_b$  value then we get a certain BER curve, if we use the slightly lower "*in the receiver*"  $E_b$  value then the  $E_b/N_0$  ratio is slightly poorer for the same BER, the curve moves to the left (closer to the theoretical curve) and the

implementation loss decreases because the loss due to the receive filters is not included. An example may help to explain this.

## G.7 Example

Creation of a signal with a specific C/N ratio in order to test the performance of an Integrated Receiver Decoder (IRD), or perhaps to degrade an incoming RF/IF signal to a specific C/N ratio in order to establish the noise margin.

To do this, add broadband white Gaussian noise "*in the channel*" to the relatively noise free RF/IF signal. Measure (or compute) the carrier power and then adjust the noise power density to give the required noise power in the selected noise power bandwidth.

Taking the following QAM system parameters as an example:

Symbol rate:	$f_S = 6,875 \text{ MHz};$
Filter roll-off:	$\alpha = 0,15;$
System noise bandwidth:	$BW_{NOISE} = 8 \text{ MHz};$
Constellation size:	$M = 64;$
Carrier power (in dB):	$C = -25 \text{ dBm}.$

then:

$$C = -25 \text{ dBm}$$

$$E_b = C - 10 \times \log_{10}(\log_2(M) \times f_S) = -101,15 \text{ dBm}$$

If a C/N ratio of 23 dB is wanted, then:

$$N = C - \left(\frac{C}{N}\right)_{dB} = -48,00 \text{ dBm}$$

$$N_0 = N - 10 \times \log_{10}(BW_{NOISE}) = -118,03 \text{ dBm}$$

So the ratio of Carrier-to-Noise applied in an 8 MHz system bandwidth at RF/IF can be described as:

$$\frac{C}{N} = 23,00 \text{ dB}$$

$$\frac{E_b}{N_0} = 16,88 \text{ dB}$$

This signal is then passed through the receiver root-raised cosine filters. The equivalent noise bandwidth of a bandpass root-raised cosine filter is equal to the symbol rate  $f_S$ . The noise power originally defined in an 8 MHz system bandwidth is reduced accordingly:

$$N_{REC} = N + 10 \times \log_{10}\left(\frac{f_S}{BW_{NOISE}}\right) = -48,66 \text{ dB} \quad (G.5)$$

The noise power density  $N_0$  is unchanged by the receive filter:

$$N_{0(REC)} = N_0 = -118,03 \text{ dBm}.$$

The signal power is already root-raised cosine shaped by the transmitter and so its power is only modified by the factor  $(1-\alpha/4)$ :

$$C_{REC} = C + 10 \times \log_{10} \left( 1 - \frac{\alpha}{4} \right) = -25,17 \text{ dB} \quad (\text{G.6})$$

The Energy-per-bit  $E_b$  is subject to this same reduction factor:  $E_{b(REC)} = -101,32 \text{ dBm}$ .

So the ratio of Carrier-to-Noise inside the receiver can be described as:

$$\frac{C_{REC}}{N_{REC}} = 23,49 \text{ dB}$$

$$\frac{E_{b(REC)}}{N_{0(REC)}} = 16,71 \text{ dB}$$

It is this received C/N (or  $E_b/N_0$ ) ratio that, when demodulated translates directly to a Signal-to-Noise Ratio (SNR) in the I/Q domain. In the idealized case that white Gaussian noise is the only impairment present then this also determines the Modulation Error Ratio (MER).

We can easily derive a general formula for the C/N modification due to the receive filters;

$$\frac{C_{REC}}{N_{REC}} = \frac{C}{N} + 10 \times \log_{10} \left[ \frac{\left( 1 - \frac{\alpha}{4} \right)}{\left( \frac{f_s}{BW_{NOISE}} \right)} \right] \text{ dB} \quad (\text{G.7})$$

and another for  $E_b/N_0$ ;

$$\frac{E_{b(REC)}}{N_{0(REC)}} = \frac{E_b}{N_0} + 10 \times \log_{10} \left[ 1 - \frac{\alpha}{4} \right] \text{ dB} \quad (\text{G.8})$$

For the C/N case the correction factor is dependent on filter roll-off, symbol rate and the system noise bandwidth used to define the noise power. However, **if the occupied bandwidth is used as the system noise bandwidth**, then equation G.7 simplifies to;

$$\frac{C_{REC}}{N_{REC}} = \frac{C}{N} + 10 \times \log_{10} \left[ \frac{\left( 1 - \frac{\alpha}{4} \right)}{\left( \frac{1}{1 + \alpha} \right)} \right] \text{ dB} \quad (\text{G.9})$$

and the correction factor becomes a constant dependent on the filter  $\alpha$  only.

$$\text{For DVB-C with filter } \alpha = 0,15 \quad \frac{C_{REC}}{N_{REC}} = \frac{C}{N} + 0,441 \text{ dB};$$

$$\text{For DVB-S with filter } \alpha = 0,35 \quad \frac{C_{REC}}{N_{REC}} = \frac{C}{N} + 0,906 \text{ dB}.$$

For comparison, if one were to always use the channel bandwidth (e.g. 8 MHz) as the system noise bandwidth then one should use equation G.7, the correction factor becomes symbol rate dependent, and ranges from +0,441 dB for a theoretical maximum occupancy symbol rate of 6,957 MBaud, through +0,492 dB for the example symbol rate of 6,875 MBaud, to +1,285 dB for a typical lower rate of 5,728 MBaud.

For the  $E_b/N_0$  case the correction for the DVB-C standard filter roll-off of  $\alpha = 0,15$  the correction factor is -0,166 dB, and for the DVB-S standard filter roll-off of  $\alpha = 0,35$  it is -0,398 dB.

It is perhaps worth mentioning that using the C/N correction formula (equation G.7) gives correction factors which suggest that the C/N is actually improved by the receive filter, but this is only because the system noise bandwidth is larger than the receiver noise bandwidth.

The  $E_b/N_0$  formula (equation G.8) more accurately reflects reality, the information-to-noise ratio is actually degraded by a small amount by the receive filter, because for the filter to pass the RF signal spectrum properly at the band edges it should also pass proportionately more noise power than signal power.

## **G.8 Signal-to-Noise Ratio (SNR) and Modulation Error Ratio (MER)**

When a randomly modulated QAM or QPSK carrier and the associated passband noise is demodulated, approximately half the signal power and half the noise power will be delivered into each baseband component channel (I and Q). The demodulation process will have a certain gain, but this gain factor will apply equally to the signal and to the noise so the resulting SNR in each channel will be approximately the same as the  $C_{REC}/N_{REC}$  ratio computed above.

The vector sum of the mean I and Q signal powers ratioed to the vector sum of the mean I and Q noise powers will, at least theoretically, be exactly the same as the  $C_{REC}/N_{REC}$  ratio computed above.

This ratio of I/Q signal power to I/Q noise power expressed in dB is the definition given in the present document for both SNR and for MER. The difference between these two measurements lies in what perturbations of the received signal are included in the computation.

When the only significant impairment is noise then SNR and MER are equivalent, and are numerically equal to  $C_{REC}/N_{REC}$ . The relationship between  $C_{REC}/N_{REC}$  and C/N depends on the choice of system noise bandwidth. If the symbol rate is chosen as the system noise bandwidth (as defined in the present document subclause 6.7) then the relationship is a fixed offset of a fraction of 1 dB as described above.

This would appear to suggest that C/N measured in the passband can be equated directly to SNR in baseband. Unfortunately other factors should also be considered in a real system. The SNR of the source modulator, the signal amplitude dependence of the noise floor of system components, and the fact that the receiver equalizer will have the effect of translating some linear impairments into noise. The exact interrelation of these parameters is the subject of further study.

## **G.9 BER vs. C/N**

As was stated in the introduction, the Bit Error Rate (BER) as a function of Carrier-to-Noise ratio (C/N) is the most important figure of merit for any digital transmission system.

To evaluate the performance of modulator and demodulator realizations, measured BER values are compared against the theoretical limits of the Bit Error Probability (BEP)  $P_B$ . Regarding DVB satellite and cable transmission schemes the BEP is usually determined based on the following assumptions:

- the only noise present is additive white Gaussian noise;
- the channel itself does not introduce any linear or non-linear distortions;
- modulator and demodulator are perfect devices (no timing errors, ideal band-limiting filters).

Based on these assumptions it is possible to calculate fairly accurate upper limits for BEP vs. C/N.

Since C/N depends on noise bandwidth it is common practice to normalize C/N by using  $E_b/N_0$  instead, where  $E_b$  is the Energy-per-bit and  $N_0$  is the noise density. The transition from one value to the other is given by:

$$\frac{E_b}{N_0} = \frac{C}{N} \times \frac{BW_{NOISE}}{f_s \times m} \quad (G.10)$$

where  $BW_{NOISE}$  is the equivalent noise bandwidth,  $f_s$  is the symbol rate, and  $m$  is the number of bits-per-symbol,  $m = \log_2(M)$ , where  $M$  is the number of constellation points. When applying this formula it is important to be consistent in using either the "in the channel" C/N or the "in the receiver" C/N values.

If Forward Error Correction (FEC) is employed, the information rate  $R_I$  is increased up to the transmission rate  $R_T$  by adding the FEC information. The relation:

$$R_C = \frac{R_I}{R_T} \quad (G.11)$$

is called the FEC rate. The transmission rate of an FEC rate 1/2 system for example will be 2 times the information rate. Therefore the "Transmission Rate"  $E_b/N_0$  will be 3 dB less than the "Information Rate"  $E_b/N_0$ , provided C/N stays constant. This results from the fact that half of the available signal power is spent on FEC information. To compensate for this effect  $E_b/N_0$  should be increased by 3 dB in case of "Information Rate" BEP. In general, if the BEP should be calculated based on the information rate,  $E_b/N_0$  should be increased by  $10 \times \log_{10}(1/R_C)$  dB.

If the performance of different FEC schemes is to be compared for power limited channels like satellite transmission, the information rate should be used because it explicitly takes into account the signal power which is used for redundancy only, and which is therefore lost for the information itself. In case of bandwidth limited channels like cable results based on the transmission rate may be more appropriate.

## G.10 Error probability of Quadrature Amplitude Modulation (QAM)

Each state in an  $M$  state QAM constellation represents a  $\log_2(M) = m$  bit symbol. For example, each state in a 64 QAM constellation represents a 6-bit symbol.

When the received signal is perturbed by Additive White Gaussian Noise (AWGN) there is a probability that any particular symbol will be wrongly decoded into one of the adjacent symbols. The Symbol Error Probability  $P_S$  of QAM with  $M$  constellation points, arranged in a rectangular set, for  $m$  even, is given by (see bibliography: Proakis, John G.: "Digital Communication", McGraw Hill, 1989):

$$P_S\left(\frac{E_b}{N_0}\right) = 2 \times \left(1 - \frac{1}{\sqrt{M}}\right) \times \operatorname{erfc}\left[\sqrt{\frac{3 \times \log_2(M)}{2 \times (M-1)} \times \frac{E_b}{N_0}}\right] \times \left\{1 - \frac{1}{2} \times \left(1 - \frac{1}{\sqrt{M}}\right) \times \operatorname{erfc}\left[\sqrt{\frac{3 \times \log_2(M)}{2 \times (M-1)} \times \frac{E_b}{N_0}}\right]\right\} \quad (G.12)$$

where  $\operatorname{erfc}(x)$  is the complimentary error function given by:

$$\operatorname{erfc}(x) = \frac{2}{\sqrt{\pi}} \int_x^{\infty} e^{-t^2} dt$$

For practical purposes equation G.12 can be simplified by omitting the, generally insignificant, joint probability term to give the approximation;

$$P_S\left(\frac{E_b}{N_0}\right) = 2 \times \left(1 - \frac{1}{\sqrt{M}}\right) \times \operatorname{erfc}\left[\sqrt{\frac{3 \times \log_2(M)}{2 \times (M-1)} \times \frac{E_b}{N_0}}\right] \quad (G.13)$$

This approximation introduces an error which increases with degrading  $E_b/N_0$ , but is still less than 0,1 dB for 64 QAM at  $E_b/N_0 = 10$  dB.

When M is not an even number (for example M = 5 (32 QAM) or M = 7 (128 QAM), then equation G.14 provides a good approximation to the upper bound on P<sub>S</sub> (see bibliography: Proakis, John G.: "Digital Communication", McGraw Hill, 1989):

$$P_S\left(\frac{E_b}{N_0}\right) \leq 1 - \left[ 1 - \operatorname{erfc}\left(\sqrt{\frac{3 \times \log_2(M)}{2 \times (M-1)} \times \frac{E_b}{N_0}}\right) \right]^2 \quad (\text{G.14})$$

As already stated, the above equations for Symbol Error Probability are based certain simplifying assumptions which can be summarized as "the system is perfect except for the presence of additive white Gaussian noise", but within this rather generous constraint the equations for P<sub>S</sub> are exact.

The corresponding Bit Error Probability (BEP) is less easily determined. It is directly related to the Symbol Error Probability (SEP) but the exact relationship depends on how many bit errors are caused by each symbol error, and that in turn depends on the constellation mapping and the use of differential encoding.

Two different approaches can be found in the literature. The first one makes no assumption about the constellation mapping and is based on the probability that any particular bit in a symbol of p bits is in error, given that the symbol itself is in error (see bibliography: Proakis, John G.: "Digital Communication", McGraw Hill, 1989 and see also Pratt, Timothy and Bostian, Charles W.: "Satellite Communications", John Wiley & Sons, 1986). This approach leads to:

$$P_B = \frac{2^{(p-1)}}{2^p - 1} \times P_S \quad (\text{G.15})$$

The other approach assumes that an erroneous symbol contains just one bit in error. This assumption is valid as long as a Gray coded mapping is used and the BER is not too high. Under these assumptions:

$$P_B = \frac{1}{p} \times P_S \quad (\text{G.16})$$

These approaches give different results for symbols of two or more bits. The second approach is generally adopted because DVB systems employ Gray code mapping. The results tabulated in annex D are based on equations G.12 and G.16.

It should be mentioned that for QAM systems DVB only employs Gray coding within each quadrant, the quadrant boundaries are not Gray coded, and the mapping is partially differentially coded. Further work is required to establish the exact P<sub>B</sub> to P<sub>S</sub> relationship for this combination of mapping and coding.

## G.11 Error probability of QPSK

QPSK can be analysed as 4 QAM. Evaluation of the general QAM equation (G.12) for M = 4 gives:

$$P_S\left(\frac{E_b}{N_0}\right) = \operatorname{erfc}\left(\sqrt{\frac{E_b}{N_0}}\right) \times \left[ 1 - \frac{1}{4} \times \operatorname{erfc}\left(\sqrt{\frac{E_b}{N_0}}\right) \right] \quad (\text{G.17})$$

Again this can be simplified by dropping the joint probability term to give:

$$P_S\left(\frac{E_b}{N_0}\right) = \operatorname{erfc}\left(\sqrt{\frac{E_b}{N_0}}\right)$$

Using the  $P_S$  to  $P_B$  relationship defined in equation G.16, the expression for  $P_B$  for QPSK modulation becomes:

$$P_B\left(\frac{E_b}{N_0}\right) = \frac{1}{2} \times \operatorname{erfc}\left(\sqrt{\frac{E_b}{N_0}}\right) \quad (\text{G.18})$$

## G.12 Error probability after Viterbi decoding

Since it is not possible to derive exact theoretical expressions for the performance of convolutional codes, only upper bounds can be presented in this annex. The upper bound:

$$P_B\left(\frac{E_b}{N_0}\right) \leq \frac{1}{k} \times \frac{1}{2} \times \sum_{d=d_f}^{\infty} w(d) \times \operatorname{erfc}\left(\sqrt{R_c \times d \times \frac{E_b}{N_0}}\right) \quad (\text{G.19})$$

provides a good approximation for infinite precision, soft decision Viterbi decoding and infinite path history, as long as  $E_b/N_0$  is not too low (see bibliography: Begin G., Haccoun D. and Chantal P.: "High-Rate Punctured Convolutional Codes for Viterbi and Sequential Decoding", IEEE Trans. Commun., vol 37, pp 1113-1125, Nov. 1989 and also see Begin G., Haccoun D. and Chantal P.: "Further Results on High-Rate Punctured Convolutional Codes for Viterbi and Sequential Decoding", IEEE Trans. Commun., vol 38, pp1922-1928, Nov. 1990).

In equation G.19,  $d_f$  specifies the free distance of the used code,  $w(d)$  can be derived from the transfer function of the convolutional code or determined directly by exhaustive search in the trellis diagram of the code,  $R_c = k/n$  is the rate of the convolutional code, and  $E_b/N_0$  is given for the transmission rate. Since  $\operatorname{erfc}(x)$  converges to zero quite quickly for increasing  $x$  only very few terms of the sum should be taken into account. Values for  $d_f$  and  $w(d)$  can be found in table G.1 regarding convolutional codes used in DVB satellite transmissions. The performance of convolutional codes for low  $E_b/N_0$  values can only be evaluated by simulations.

**Table G.1: Free distance and weights  $w(d)$  for DVB convolutional codes**

Code Rate $R_c$	1/2	2/3	3/4	5/6	7/8
free distance $d_f$	10	6	5	4	3
$w(d_f)$	36	3	42	92	9
$w(d_f+1)$	0	70	201	528	500
$w(d_f+2)$	211	285	1 492	8 694	7 437
$w(d_f+3)$	0	1 276	10 469	79 453	105 707
$w(d_f+4)$	1 404	6 160	62 935	791 795	1 402 089
$w(d_f+5)$	0	27 128	379 546	7 369 828	17 888 043
$w(d_f+6)$	11 633	117 019	2 252 394	67 809 347	221 889 258
$w(d_f+7)$	0	498 835	13 064 540	609 896 348	2 699 950 506
$w(d_f+8)$		2 103 480	75 080 308	5 416 272 113	32 328 278 848
$w(d_f+9)$		8 781 268	427 474 864	47 544 404 956	382 413 392 069

### G.13 Error probability after RS decoding

A Reed-Solomon (RS) code is specified by the number of transmitted symbols (note) in a block  $N$  and the number of information symbols  $K$  (see bibliography: Odenwalder J.P.: "Error Control Coding Handbook", Final report prepared for United States Airforce under Contract No. F44620-76-C-0056, 1976).

Such a code will be able to correct up to  $t = (N-K)/2$  symbol errors. As for DVB transmission  $N = 204$  and  $K = 188$  are used. Therefore up to  $t = 8$  erroneous symbols can be corrected.

NOTE: Whereas the symbols mentioned in context with QAM and QPSK are related to the modulation the symbols mentioned here are just a group of bits.

The probability  $P_{BLOCK}$  of an undetected error for a block of  $N$  symbols as a function of the error probability of the incoming symbols  $P_{SIN}$  is given by:

$$P_{BLOCK} = \sum_{i=t+1}^N \binom{N}{i} \times P_{SIN}^i \times (1 - P_{SIN})^{N-i} \quad (G.20)$$

From this expression the probability:

$$P_S = \frac{1}{N} \times \sum_{i=t+1}^N \beta_i \times \binom{N}{i} \times P_{SIN}^i \times (1 - P_{SIN})^{N-i} \quad (G.21)$$

of a symbol error can be derived, where  $\beta_i$  is the average number of symbol errors remaining in the received block given that the channel caused  $i$  symbol errors. Of course  $\beta_i = 0$  for  $i \leq t$ . When  $i > t$ ,  $\beta_i$  can be bounded by considering that if more than " $t$ " errors occur, a decoder which can correct a maximum of " $t$ " errors will at best correct " $t$ " of the errors and at worst add " $t$ " errors. So:

$$i - t \leq \beta_i \leq i + t \quad (G.22)$$

is the possible range for  $\beta_i$ . A good approximation is  $\beta_i = i$  but also  $\beta_i = t + i$  is used, which can be regarded as an upper limit. From G.21 the BEP can be calculated by using G.15 or G.16.

### G.14 BEP vs. C/N for DVB cable transmission

For DVB transmission in cable networks, QAM-M systems with  $M = 16, 32$  and  $64$  are specified. To evaluate the BEP after RS decoding, the following steps should be done:

- a) calculate the SEP after QAM demodulation by using G.12 or G.14;
- b) transform the SEP into a BEP by applying G.15 or G.16 to the SEP with  $p = m$ ;
- c) transform the resulting BEP into a SEP with  $p = 8$  by using G.15 or G.16;
- d) use G.21 to calculate the SEP PS after RS decoding;
- e) apply G.15 or G.16 to  $P_S$  with  $p = 8$  to determine the final BEP;
- f) if the BEP should be based on the information rate, shift the curve by:

$$10 \times \log_{10}(204/188) = 0,35 \text{ dB to the right.}$$

If just the BEP before Reed-Solomon is needed, only the first two steps are necessary. In this case there is no difference between information rate and transmission rate. All bits are regarded as information bits.

The limits before and after Reed-Solomon decoding for  $M = 64$ ,  $\beta_i = i$  and  $E_b$ , based on the transmission rate, are presented in Figure G.1.

## 64-QAM Demodulation and Reed Solomon Decoding

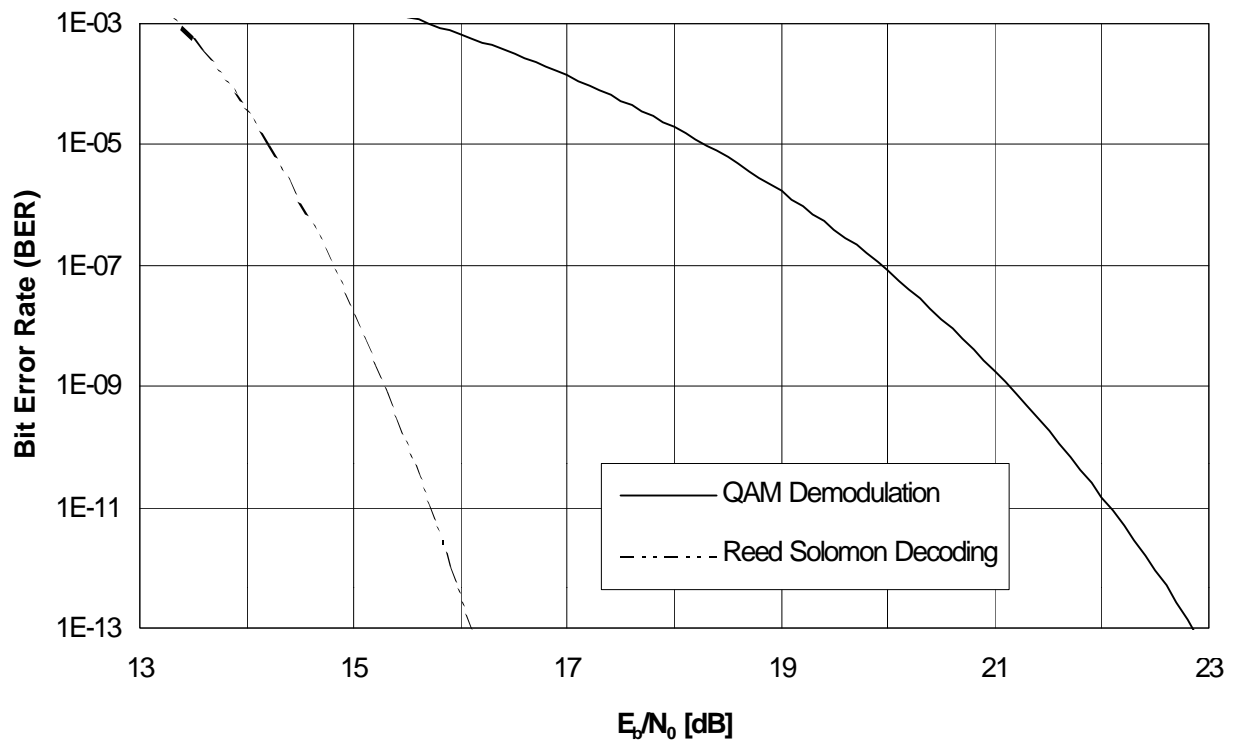

Figure G.1: BER for QAM-64 DVB cable transmission

### G.15 BER vs. C/N for DVB satellite transmission

For satellite transmission three different BEPs are possible:

- BEP after QPSK demodulation;
- BEP after Viterbi decoding;
- BEP after Reed-Solomon decoding.

The BEP after QPSK can be derived from G.17. There is no difference to be made between information bit rate and transmission bit rate.

The BEP after Viterbi decoding is expressed by G.18. The result is based on the information rate, because RC is taken explicitly into account in G.18.

BEP after Reed-Solomon decoding can be derived from the above result by applying the following steps to the outcome of G.18:

- a) transform the BEP after Viterbi decoding into a SEP by using G.15 or G.16 with  $p = 8$ ;
- b) use G.17 to determine the SEP after Reed-Solomon decoding;
- c) apply G.15 or G.16 to  $P_S$  with  $p = 8$  to determine the final BEP;
- d) if the BEP should be based on the information rate, shift the curve by:

$$10 \times \log_{10}(204/188) = 0,35 \text{ dB to the right.}$$

The results for the three different BEPs and for all the different code rates  $R_c$  are presented in Figure G.2.

## QPSK Demodulation, Viterbi and Reed Solomon Decoding

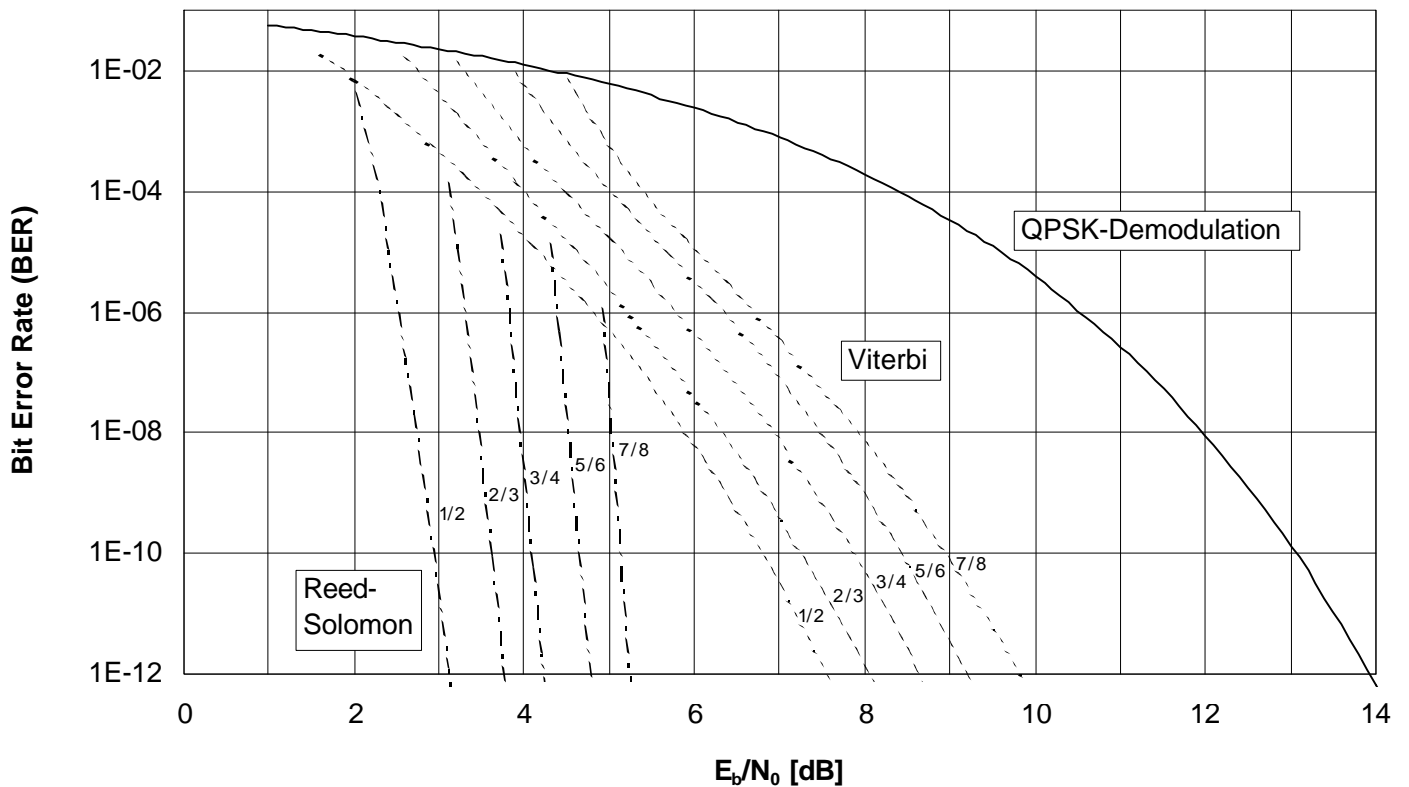

**Figure G.2: BER for DVB satellite transmission**

Since it is common practice in satellite transmission to refer the results to the information rates the curves for BEP after Reed-Solomon decoding have been shifted  $E_b$  accordingly. The expression G.19 is only valid for low error rates. Despite the fact that for decreasing  $E_b/N_0$  the BER should converge to  $1/2$  the results according to G.19 will possess a singularity for  $E_b/N_0 = 0$ . This behaviour is especially pronounced for  $R_c = 7/8$ , where the assumption of a low error rate is not fulfilled above a BEP of  $10^{-4}$ .

### G.16 Adding noise to a noisy signal

In a practical situation where we deliberately add noise to real signal in order to create a specific C/N ratio for measurement purposes, it is important to realize that there are two fundamental assumptions implicit in this technique.

The first assumption is that the input signal has a high C/N ratio and can, for practical purposes, be regarded as carrier only. The second assumption is that the input signal has a considerably better C/N ratio than the C/N ratio we wish to generate. In practice we may be adding noise to an already noisy signal, and in this case there are accuracy issues related to the above assumptions that should be considered.

First consider how noise is typically added to a signal. Figure G.3 gives a simplified block diagram:

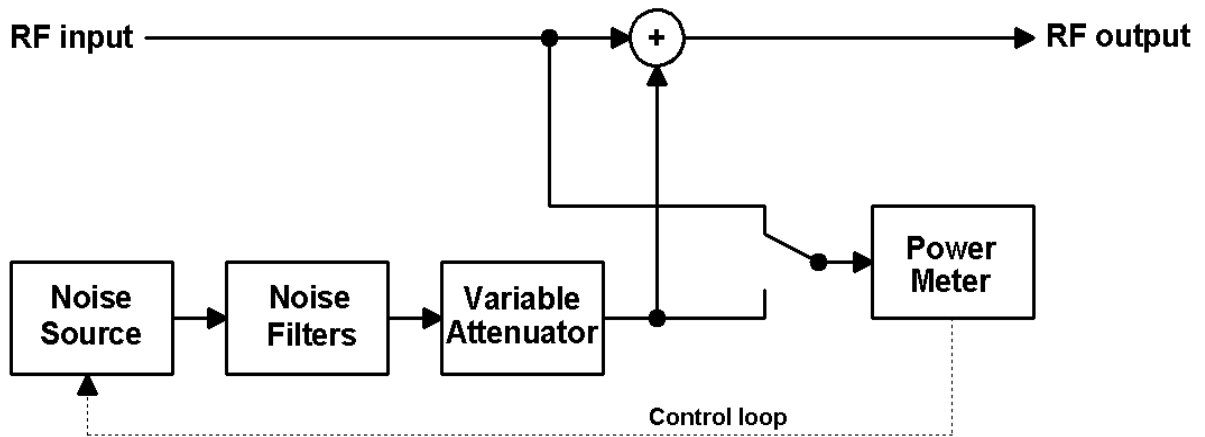

**Figure G.3: Simplified block diagram of C/N test set**

The input is the carrier signal to be impaired. The carrier power is measured using the power metre. A broadband Gaussian noise source is then filtered and attenuated appropriately to deliver the required noise density ( $N_0$ ) across the frequency band of interest. The same power metre is used to set the noise power which helps ensure good  $C/N_0$  ratio accuracy. The generated noise is added to the input signal to achieve the required  $C/N_0$  ratio in the output signal. Finally, the carrier power is monitored and the power of the noise source is adjusted accordingly to maintain the required  $C/N_0$ .

In automated versions of this process, the user simply selects the desired  $C/N_0$  ratio. This can be entered as  $C/N_0$ , but it is more typically entered as  $C/N$  which requires that the user also enters the receiver or system noise bandwidth, or it can be input as  $E_b/N_0$  which requires that the user also enters the system bit rate.

From this description it is evident that it is assumed that all the measured input power is carrier and the noise power to achieve the required  $C/N$  ratio is computed accordingly. If the input already contains some noise or other carriers then this will:

- a) appear at the output in addition to the generated noise;
- b) cause the generated noise power to be too large because it is based on the  $C + N$  power at the input, not just the  $C$  power. This error is exacerbated if the input is not band limited.

We can derive a formula for the actual output  $C/N$  ratio as a sum of the theoretical  $C/N$  ratio and an error term:

$$CN_{actual} = 10 \times \log_{10} \left[ \frac{C}{N} \right] - 10 \times \log_{10} \left[ \frac{N_c}{N_i + N_c + N_n} \right] \text{ dB} \quad (\text{G.23})$$

*theoretical C/N ratio*
*error term*

Where  $N_c$  is the noise power added due to the carrier power,  $N_i$  is the noise power already present in the input,  $N_n$  is the noise power added due to the input noise. If we perform further manipulation of the error term then we arrive at an expression in terms of the fractional input and output  $C/N$  ratios.

$$CN_{error} = 10 \times \log_{10} \left[ \frac{1}{\frac{1}{CN_{in}} + \frac{CN_{out}}{CN_{in}} + 1} \right] \text{ dB} \quad (\text{G.24})$$

The error becomes significant if either the  $1/CN_{in}$  or the  $CN_{out}/CN_{in}$  term in the denominator moves away from zero which will happen if either the  $C/N_{in}$  ratio or the  $C/N_{out}$  to  $C/N_{in}$  margin is reduced.

The present document gives a minimum value of 15 dB for the  $C/N_{in}$  ratio and for the  $C/N_{out}$  to  $C/N_{in}$  margin as a guideline figure. To meet this condition in satellite systems it is necessary to use a sufficiently large dish to get the required C/N ratio. A received C/N ratio of 20 dB or more is desirable.

Alternatively, it is possible to work with higher noise signals if it is possible to measure the carrier and noise power accurately, for example by measuring carrier plus noise then switching off the carrier and measuring noise only. Equation G.23 can then be used to compensate for the errors due to the input noise.

## **Annex H: Bibliography**

- Proakis John G.: "Digital Communication", McGraw Hill, 1989.
- Begin G., Haccoun D. and Chantal P.: "High-Rate Punctured Convolutional Codes for Viterbi and Sequential Decoding", IEEE Trans. Commun., vol 37, pp 1113-1125, Nov. 1989.
- Begin G., Haccoun D. and Chantal P.: "Further Results on High-Rate Punctured Convolutional Codes for Viterbi and Sequential Decoding", IEEE Trans. Commun., vol 38, pp 1922-1928, 1990.
- Odenwalder J.P.: "Error Control Coding Handbook", Final report prepared for United States Airforce under Contract No. F44620-76-C-0056, 1976.
- Pratt, Timothy and Bostian Charles W.: "Satellite Communications", John Wiley & Sons, 1986.