



INTERFACES FOR DVB-IRD

DVB DOCUMENT A016 rev. 1
February 1997

Reproduction of the document in whole or in part without prior permission of the DVB Project Office is forbidden.

TABLE OF CONTENTS

1 SCOPE	3
2 NORMATIVE REFERENCES	3
3 EXPLANATION OF TERMS AND ABBREVIATIONS.....	6
4 INTERFACE REQUIREMENTS FOR DVB-IRDS.....	7
4.1 RF INPUT IN THE SATELLITE IF RANGE	7
4.2 RF I/O IN THE VHF/UHF RANGE	7
4.3 MODEM INTERFACE.....	7
4.4 VIDEO SIGNALS.....	9
4.5 AUDIO SIGNALS	10
4.6 DATA SIGNALS.....	10
4.7 CONTROL SIGNALS.....	12
4.8 INTERFACE FOR DETACHABLE COMMON ACCESS MODULE.....	13
4.9 CONNECTORS	14
ANNEX 1 (INFORMATIVE)	16
CONFIGURATION EXAMPLES	
ANNEX 2 (INFORMATIVE)	24
CATV CHANNEL ASSIGNMENTS	

INTERFACES FOR DVB-IRD

1 Scope

This specification is an application standard, identifying recommended interfaces for connections of digital video broadcast integrated receiver decoder (DVB-IRD) equipment. If a recommended interface is supported, then the full specification of that interface, which may include options, applies. Interfaces not mentioned in this document are not excluded, and especially interfaces which are under development at the time of writing of this document may be added at a later stage.

For mechanical and electrical details of the interfaces, reference is made to existing standards of IEC or Cenelec wherever possible, or standards which are known to be in an advanced state of development.

2 Normative References

2.1 DVB Baseline documents

A007

Common Interface Specification for Conditional Access and other Digital Video Broadcasting Decoder Applications.

2.2 IEC Publications

IEC 169-2 Radio frequency connectors, Part 2: coaxial unmatched connector

IEC 169-24 Radio Frequency connectors, Part 24: Radio frequency coaxial connectors with screw coupling, typically for use in 75 Ohm cable distribution systems (type F).

IEC 807-9 Rectangular connectors for frequencies below 3 MHz, Part 9: Detail specification for a range of peritelevision connectors.

IEC 870-5 Telecontrol Equipment and Systems, Part 5: Transmission protocols

IEC 933-0 Preferred matching values for analog signals

NOTE - This standard is being developed within the Program of Work of WG7 of IEC/SC100C. At the time of this writing the latest version is 84/421/CDV, whereas the FDIS will circulate for international approval shortly.

IEC 933-1 Audio, video and audiovisual systems, interconnections and matching values, Part 1: 21 contact connector for video systems, application No 1

IEC 933-5 Audio, video and audiovisual systems, interconnections and matching values, Part 5: Y/C connector for video systems

IEC 958 Digital audio interface

IEC 1030 Audio, video and audiovisual systems, Domestic digital bus (D2B)

IEC 1319-1 Interfaces for satellite receiving equipment, Part 1: Europe.

IEC 1602 Connectors used in the field of audio, video and audiovisual engineering

NOTE - This Technical Report is being developed within the Program of Work of WG7 of IEC/SC100C. At the time of this writing the latest version is 84/418/CDV, whereas the publication is envisaged during 1Q 1996.

IEC 1883 Digital interface for consumer electronic audio/video equipment.

NOTE - This specification is currently being developed within the Program of Work of WG11 of IEC/SC100C.

IEC 1937 Interface for multichannel non-PCM encoded audio bitstreams

NOTE - This standard is being developed within the Program of Work of WG11 of IEC/SC100C. At the time of this writing the latest version is the first draft attached to 100C/3/NP.

2.3 Cenelec Publications

EN50049-1 Domestic and similar electronic equipment interconnection requirements: Peritelevision connector

prEN50157-1 AVLink, Part 1: Signal quality matching and automatic deselection of source devices

prEN50090 Home and Building Electronic Systems

NOTE - This standard used to be under development within Cenelec TC205. Implementation 3: ESPRIT Home Systems, is referenced to as relevant to DVB-IRD.

2.4 Publications by ETSI

ETS 300 158 Satellite Earth Stations; television receive-only, FSS

ETS 300 249 Satellite Earth Stations; television receive-only, BSS

ETS 300 421
Digital broadcasting systems for television, sound and data services;
Framing structure, channel coding and modulation for 11/12 GHz satellite services

ETS 300 429
Digital broadcasting systems for television, sound and data services;
Framing structure, channel coding and modulation for cable systems

ETS 300 473
Digital Broadcasting Systems for television, sound and data services; Satellite Master Antenna Television (SMATV) distribution systems.

2.5 Industrial publications

PCMCIA
PC Card Standard, release 3, Personal Computer Memory Card International Association, Sunnyvale, Cal.

IEEE 1394 Standard for a high performance serial bus

IEEE 1284 (1994)
Signalling method for a bi-directional parallel peripheral interface for personal computers.

ANSI/EIA RS232

Interface between data terminal equipment and data-circuit terminating equipment employing serial binary data interchange

NOTE - The latest version of this standard is published as RS232E (1991).

3 Explanation of terms and definitions

The following special terms and abbreviations are used in this Standard:

DVB Digital video broadcast

IRD Integrated receiver decoder

LNB Low noise block converter

CATV Community Antenna Television system:
A system designed primarily to provide sound and television signals to communities.

SMATV Satellite Master Antenna Television system:
A system designed to provide sound and television signals to the households of a building or group of buildings. Two system configurations are defined in ETS 300 473 as follows:

- SMATV system A, based on transparent transmodulation of QPSK satellite signals into QAM signals to be distributed to the user
- SMATV system B, based on direct distribution of QPSK signals to the user, with two options:
 - SMATV-IF distribution on the satellite IF band (above 950 MHz)
 - SMATV-S distribution on the VHF/UHF band, for example the extended S-band (230-470 MHz)

IEC International Electrotechnical Commission

Cenelec Commission Européenne de Normalisation Electrotechnique

ETSI European Telecommunication Standardisation Institution

CVBS Composite video, blanking and sync

VPS Video Programming System

DTE/DCE Data Terminal Equipment / Data Communication Equipment

ADSL Asymmetric digital subscriber loop

PSTN Public Switched Telephone Network

DVC Digital Video Cassette

BSS Broadcast Satellite Services

FSS Fixed Satellite Services

4 Interface requirements for DVB-IRDs

4.1 RF input in the satellite IF range

This clause specifies the interface in case of individual dish antenna or SMATV-IF (analog and digital) installations.

- 4.1.1 The control signal to switch the polarisation, the control signal to select the upper or lower band of the LNB, and the 1st IF input from the LNB to the DVB-IRD shall be as specified in IEC 1319-1, clause 5. The connector is specified in IEC 169-24 (also known as the F-connector), the impedance is 75 Ohm, and output return losses are specified in ETS 300 158 and ETS 300 249.
- 4.1.2 The control signal for the azimuth control of a polar mount dish antenna shall be as specified in IEC 1319-1, clause 6.

4.2 RF i/o in the vhf/uhf range

- 4.2.1 RF input in the case of CATV installations, SMATV System A or SMATV-S installations, or in the case of terrestrial reception.

RF input shall be as follows:

- covers the vhf/uhf frequency bands (47-862 MHz)
- 75 Ohm coaxial
- connector IEC 169-2, female connector on the DVB-IRD

4.2.2 RF output

The interface for RF output signals shall be as specified in clause 4.2.1 except for the connector which is IEC 169-2 male version. RF output shall support either loop through only, or RF modulated output from the DVB-IRD, or both. In case of loop through the modulator should output the vhf/uhf frequency bands as specified in 4.2.1. The channel to be used for RF modulated output depends on local circumstances, i.e. occupation of available channels by either terrestrial or cable programmes. (see informative Annex 2). It is recommended to support the channel range 21 to 69 in UHF.

4.3 Modem interface

4.3.1 PSTN modem

A PSTN modem interface provides a low bit rate data channel.

4.3.1.1 External modem

4.3.1.1.1 DTE/DCE interface

The modem shall support:

- a) An interface lead with a 9 pin D-type connector with male shell and female contacts, using RS232C interface levels. The DVB-IRD is seen as the Data Termination Equipment (DTE) and shall be equipped with the mating connector. The pin arrangement shall be as follows:

pin number	name	function	Source
1	DCD	Carrier Detection	modem
2	RXD	Receive Data	modem
3	TXD	Transmit Data	IRD
4	DTR	Data Terminal Ready	IRD
5	GND	Signal Ground	
6	DSR	Data Set Ready	modem
7	RTS	Request To Send	IRD
8	CTS	Clear To Send	modem
9	RI	Ring Indicator	modem

- b) Automode selection CCITT V.21, V.23 (1200/75), V.22 or V.22 bis transmission protocols (one of these as a minimum). Asynchronous working with one or two stop bits and with or without parity shall be possible. It is recommended that V.32, V.32 bis and V.34 support is included and that the design does not preclude the addition of future enhancements.
- c) Hardware flow control (RTS/CTS) in addition to XON/XOFF flow control
- d) Control by the Hayes AT command set.
- e) Autocalling, CCITT V.25 autoanswering and an autologon feature.
- f) CCITT V.42 error correction and V.42.bis data compression.

NOTE - V.25 and V.42 are optional extras for a modem interface.

4.3.1.1.2 PSTN link interface

The modem shall be equipped with RJ45 (6 contact) connector with pin arrangement as follows:

pin number	name	function
1		
2		
3		
4		
5		
6		

NOTES

1 - PSTN (GSTN) working implies using a PSTN interface cable terminating in a plug which meets national connection requirements given in ETS 300 001 (NET4). The compliance to this interface implies the need for the product to be subjected to type approval by the National regulatory body.

2 - Approval under the Terminal Equipment Directive 91/263/EEC.

4.3.1.2 Integrated modem

The internal modem shall meet the same requirements as the external modem as specified in 4.3.1.1 with the exception of providing the 9 pin interface connector as specified in 4.3.1.1.a).

4.3.2 CATV and SMATV modem

A CATV/SMATV modem interface provides a bi-directional data channel. The suitable data rate and the kind of operation depends on the performance of the service.

4.3.2.1 DTE/DCE interface

An external modem shall be equipped with an interface lead with a 9 pin D-type connector with male shell and female contacts, using RS232 interface levels. The DVB-IRD is the Data Termination Equipment (DTE) and shall be equipped with the mating connector. The pin arrangement shall be as follows:

pin number	name	function	Source
1			
2	RXD	Receive Data	modem
3	TXD	Transmit Data	IRD
4			
5	GND	Signal Ground	
6			
7			
8			
9			

4.3.2.2 RF interface to CATV/SMATV network

The RF interface for both an internal and an external modem shall be as follows:

impedance 75 Ohm
connector IEC 169-2, female on the modem

It is recommended to use for the carrier in the forward direction:

- a) for CATV, SMATV System A and SMATV-S modem the range of 47 MHz to 862 MHz;
- b) for SMATV-IF modem the range above 850 MHz.

It is recommended to use for the carrier in the return direction the range of 5 MHz to 65 MHz (to be confirmed).

The choice of carrier frequencies depends on the design of the CATV/SMATV network.

4.4 video signals

Analog video signal output can be either baseband in RGB, Y/C (S-VHS) or CVBS format, or modulated on an RF carrier. The MPEG2 Transport Stream is used to transmit the digital video signals on a high performance serial interface, see clause 4.6.3

4.4.1 Baseband signals

Matching values for analog baseband signals $1V_{pp}$. For detailed specifications see any one of the following standards:

- IEC Interface: Preferred matching values for analog signals.
- IEC 933-1: 21 contact connector
- EN 50049-1: Peritelevision connector
- prEN50157-1: AVLink

NOTES

1 - All CVBS related features from PAL services (like VPS, teletext) which are available on the Peritelevision connector should be made available as usual.

For teletext there are two possibilities:

- the set top box contains a teletext decoder, and provides teletext output as OSD in RGB output signals
- the set top box does not contain a teletext decoder, in which case teletext information is provided in the VBI of the CVBS output signal.

2 - The DVB standard also provides 2.21:1 (20:9) aspect ratio as an option for the receiver. While displays will only support 4:3 or 16:9, the aspect ratio 2.21:1 will result in a letterbox format. The Peritelevision connector provides following options to deal with aspect ratio 2.21:1 (20:9):

- 6 V signal level on function switch contact 8 is specified to correspond to 16:9 aspect ratio (see EN50049-1). For optional 20:9 signals the IRD should apply suitable processing as detailed in TM1214 Revision 3 for display on 4:3 and 16:9 display units.
- the protocol on contact 10 (see prEN50157-1) includes the option to signal ">16:9". This, when used by the DVB-IRD, will result in proper handling by a 16:9 display unit.

Connectors:

- Peritelevision connector, see IEC 807-9
- Phono connector
- 4 contact connector, see IEC 933-5

4.4.2 RF modulated signals

Video output is also implied in the RF modulated output as described in clause 4.2.2.

4.5 audio signals

Audio signal output can be in either analog or digital format, or modulated on RF carrier.

4.5.1 Analog audio signals

Matching values: 0,5 to 2 V, see IEC 933-0: Preferred matching values for analog signals.

Connector:

- Peritelevision, see IEC 807-9
- Phono connector

4.5.2 Digital audio signals

4.5.2.1 Linear PCM coded audio signals.

This shall be compliant to IEC 958.

NOTE - In case the DVB-IRD includes a surround sound decoder, the multiple analog outputs thereof would require a number of Phono outputs as identified in clause 4.5.1.

4.5.2.2 Compressed and multichannel audio signals

If compressed and multichannel audio signals are transmitted on IEC 958 then the application specification is based on future IEC 1937.

For other MPEG based audio signal transport see clause 4.6.3.

4.5.3 RF modulated signals

Audio output (mono only) is also implied in the RF modulated output as described in clause 4.2.2.

4.6 data signals output

Three interface options are envisaged, each accomodating a range of bit rates and services, i.e. RS232 for low bitrates, IEEE 1284 for bit rates up till about 10 Mb/s, and IEEE 1394 for bit rates of 100 Mb/s or more such as MPEG-2 compressed streams or other multimedia data streams.

4.6.1 Low bitrate serial data port.

This interface can be used to interface to a PC or to other terminals for data including still video images and software.

The DVB-IRD shall be equipped with an interface with a 9 pin D-type socket with female contacts, using RS232C interface levels. The pin arrangement shall be as follows:

pin number	name	function	Source
1			
2	RXD	Receive Data	IRD
3	TXD	Transmit Data	PC
4			
5	GND	Signal Ground	
6			
7	RTS	Request To Send	PC
8	CTS	Clear To Send	IRD
9			

The IRD is seen as a Data Communication Equipment (DCE) and the PC (or other terminal) is seen as the Data Terminal Equipment (DTE).

The interface shall support full duplex data transfer, and hardware flow control (RTS/CTS) as well as XON/XOFF flow control

This interface supports standard data rates up till 19,2 kb/s, whereas, dependent on length and quality of cable, data rates up till in the order of 100 kb/s are also possible.

4.6.2 High bit rate parallel data port

This interface shall comply with IEEE 1284 standard.

Equipment connector: D-type connector, female 25 pins.

It shall be possible to adapt the interface to the capability of the connected equipment. The parallel interface shall be bi-directional with the data transfer directed to and from an external device (e.g. a computer, a printer or CD-ROM).

NOTE - The Centronics control functions are active in the direction opposite to the data transfer.

Data rates up to 10 Mb/s shall be supported.

The pin arrangement shall be as follows:

pin no	name	function	input or output
1	strobe	data transition detection	i
2	D0	Data bit 0	i/o
3	D1	Data bit 1	i/o
4	D2	Data bit 2	i/o
5	D3	Data bit 3	i/o
6	D4	Data bit 4	i/o
7	D5	Data bit 5	i/o
8	D6	Data bit 6	i/o
9	D7	Data bit 7	i/o
10	/ACK	/Acknowledge	o
11	BUSY	Busy	o
12	PE	Paper End	o
13	SLT	Select	o
14	AUTO F	Auto Feed	i
15	/ERROR	/Error	o
16	/INIT	/Initialise	i
17	/SLCT IN	/Select In	i
18	GND	Ground	
19	GND	Ground	
20	GND	Ground	
21	GND	Ground	
22	GND	Ground	
23	GND	Ground	
24	GND	Ground	
25	GND	Ground	

The electrical characteristics of the parallel interface shall be compliant with the level 2 electrical interface defined in IEEE 1284.

The IRD shall handle the following modes defined in IEEE 1284: "compatibility mode", "Nibble mode", "Byte mode" and "ECP mode". The handling of the "EPP mode" is not required.

The identification of the external function (device ID string) is not required.

For the "ECP mode" the handling of the RLE (run length encoding) compression is not required.

4.6.3 High speed serial interface

This interface provides high bit rate of 100 Mb/s or more for MPEG-2 compressed streams or other multimedia data streams.

The physical, link and transport layers shall be compliant to the cable environment as specified in IEEE 1394.

The following options apply to the DVB-IRD application:

- bitrates of 100 Mb/s shall be supported. Extension to 200 Mb/s or 400 Mb/s is optional.
- the powerlines may be deleted, reducing the interface to a 4 wire version for CE A/V purposes, see IEC1883.
- preferably an IRD should show at least two 1394 ports.
- the IRD shall be capable of acting as root and performing the isochronous resource management functions.

The packet layer and data format for MPEG2 transport capability shall be compliant to IEC 1883.

4.7 Physical interfaces for control signals

Control signals may be embedded in interfaces for data signals, in which case the physical interface for those data signals also apply to the control signals.

Other interfaces, dedicated to the transmission of control signals, may also be used. These interfaces, if used, shall be compliant to one of the following standards:

- IEC 1030 (D2B)
- prEN50157-1, control protocol through contact 10
- relevant transmission media of Home Systems (coax and twisted pair)

4.8 Interface for detachable conditional access module.

A conditional access system may be needed to provide access to a broadcast service. One solution for a conditional access system is a detachable module based on a standardised interface between a module and a host equipment as fully specified in A007. The physical characteristics of this interface, which uses the PCMCIA specification, are described in Annex A of A007.

Other interfaces are known to be under consideration.

4.9 Connectors

The following table provides a list of connectors, pin assignments and signals which are relevant to this standard.

Connector type, and standard	pin assignment		Connector application / interface standard
	pin nr	signal	
F-type IEC 169-24	--	1st IF from roof top unit	none
rf type IEC 169-2	--	vhf/uhf from Yagi or CATV	IEC 574-3
4 pin Y/C IEC 1076-4-105	3(1) 4(2)	Y signal C signal	IEC 933-5
Peritelevision IEC 807-9	1,2,3,6 (4)	audio	IEC 933-1 EN 50049-1 and Amendments prEN 50157-1
	15(13), 11(9), 7(5)	R/C,G,B/C in/out	
	16 (..)	fast blanking	
	19(17)	CVBS/Y out	
	20(18)	CVBS/Y in	
	8	function switch	
	10(21)	control signal line (prEN50157-1 only)	
	12	reserved	
phono ¹	--	digital audio	IEC 958
phono	--	analog audio	IEC 268-11 IEC 574-3
D2B ²		D2B	IEC 1030
9 pin D-type ³	1	DCD Carrier Detect	
	2	RXD Receive Data	
	3	TXD Transmit Data	
	4	DTR Data Terminal Ready	
	5	GND Signal Ground	
	6	DSR Data Set Ready	
	7	RTS Request To Send	
	8	CTS Clear To Send	
	9	RI Ring Indicator	
PCMCIA	see PCMCIA documentation		
IEEE 1394	2 TP (data and timing) power (optional)		IEEE 1394
25 pin D-type			IEEE 1284

NOTE - pin numbers between brackets indicate signal return connections

Table 1 - survey of connectors and pin assignments, used in this standard

¹ A detailed component specification of the "Phono" connector does not exist.

² A detailed component specification of the D2B connector does not exist.

³ Note that this standard specifies three applications of this connector, each with its own subset of the signals.

Annex 1 (informative)

Configuration examples

The following diagrams provide examples of DVB-IRD products, featuring the interfaces as specified in this standard. Each version, featuring a certain sub set of the interfaces specified in this standard, can be seen as being specific for a certain market segment. It is left to individual manufacturers to select a certain combination of interfaces in order to reach a certain market segment.

Figure A1 is a generic diagram showing all interface options. Figures A2, A3 and A4 illustrate the configuration of first generation DVB-IRD devices employing analog interfaces, whereas figure A5, A6 and A7 illustrate configurations based on digital interfaces.

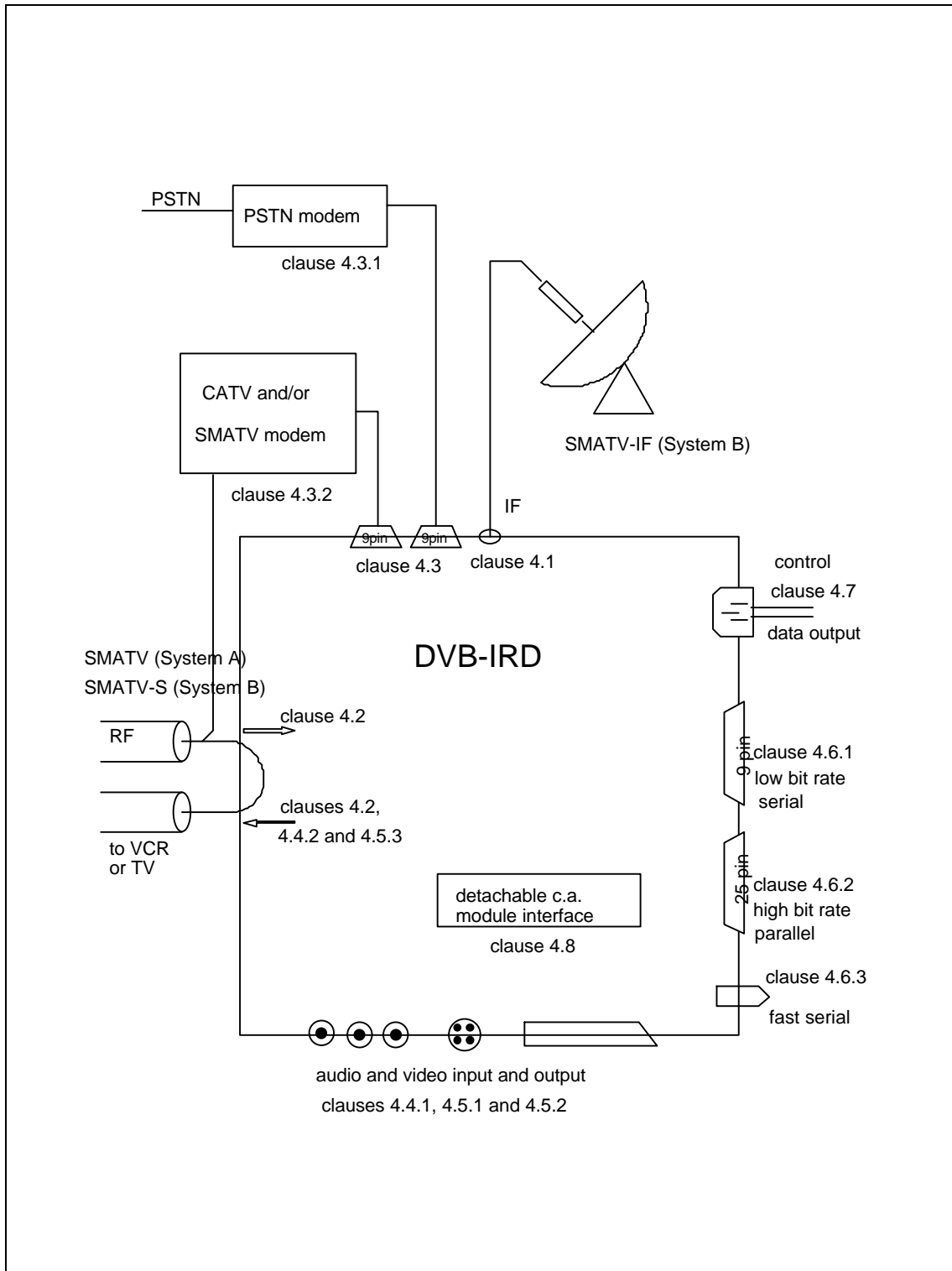

Figure A1: Generic diagram, showing all optional interfaces

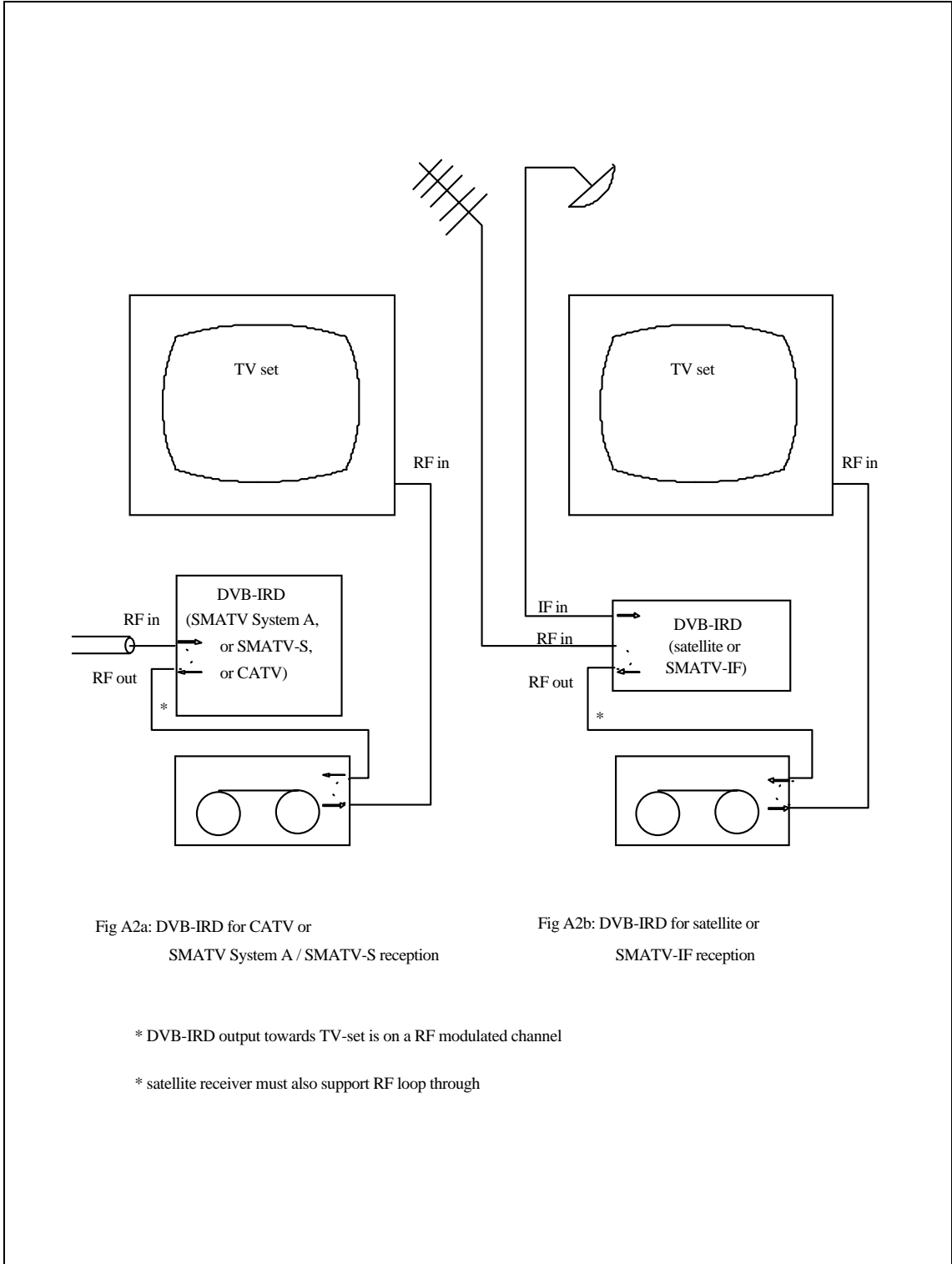

Figure A2: Typical low end configuration

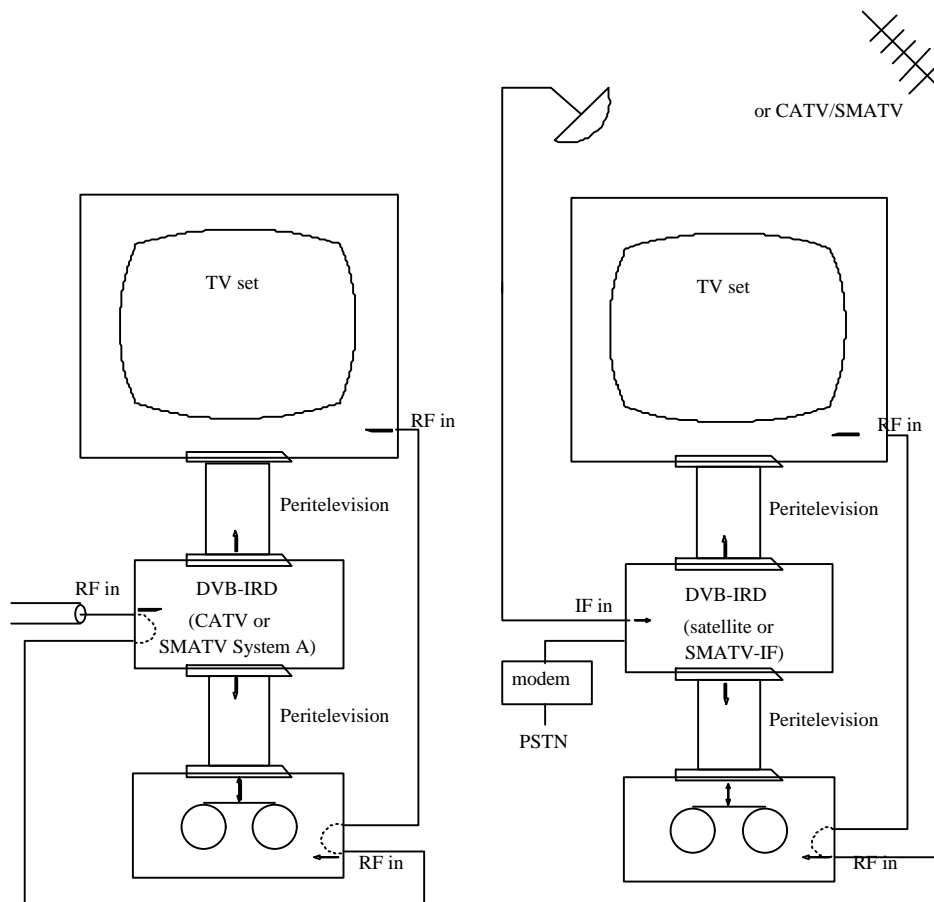

Fig A3a: DVB-IRD for CATV or SMATV System A reception

Fig A3b: DVB-IRD for satellite or SMATV-IF reception

- * Peritelevision connections in accordance to EN 50049-1
- * DVB-IRD must provide Peritelevision loop through for recorder to TV set
- * control of Peritelevision connections through function switch on contact 8
- * DVB-IRD (cable) must provide vhf/uhf antenna loop through

Figure A3: Typical "mid range" configuration

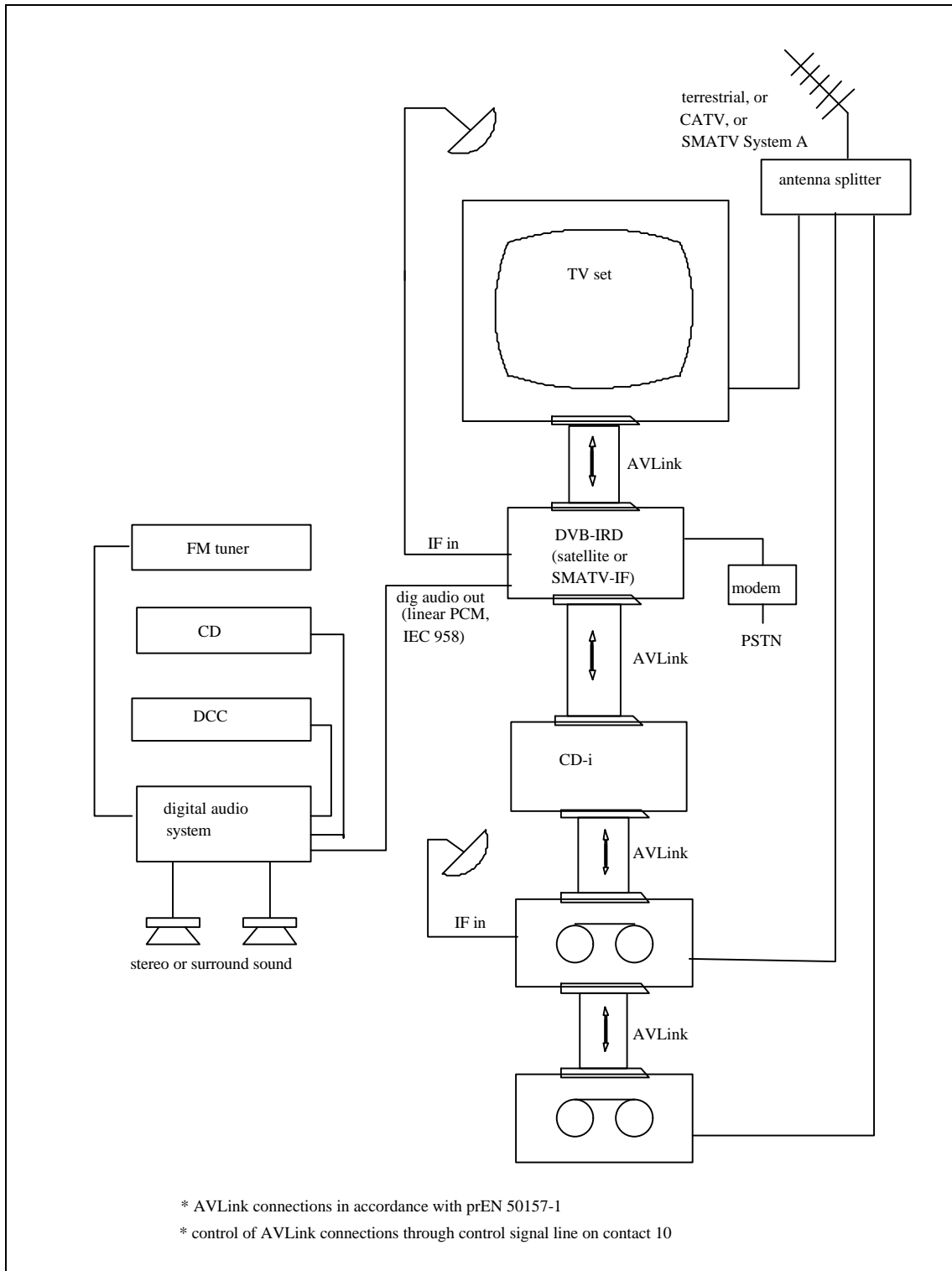

Figure A4: Possible high end configuration.

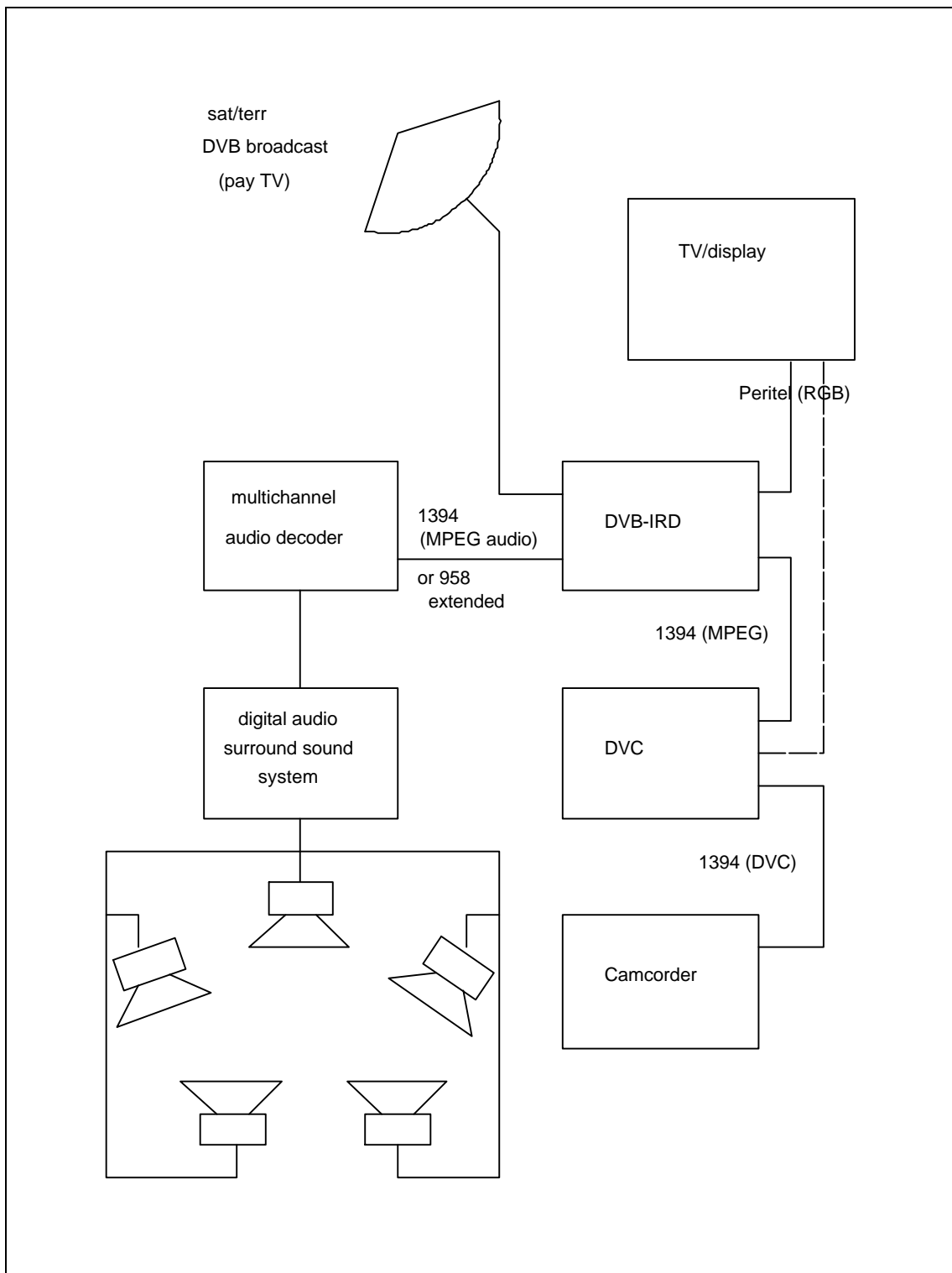

Figure A5: Example of DVB-IRD broadcast configuration with high speed serial interface

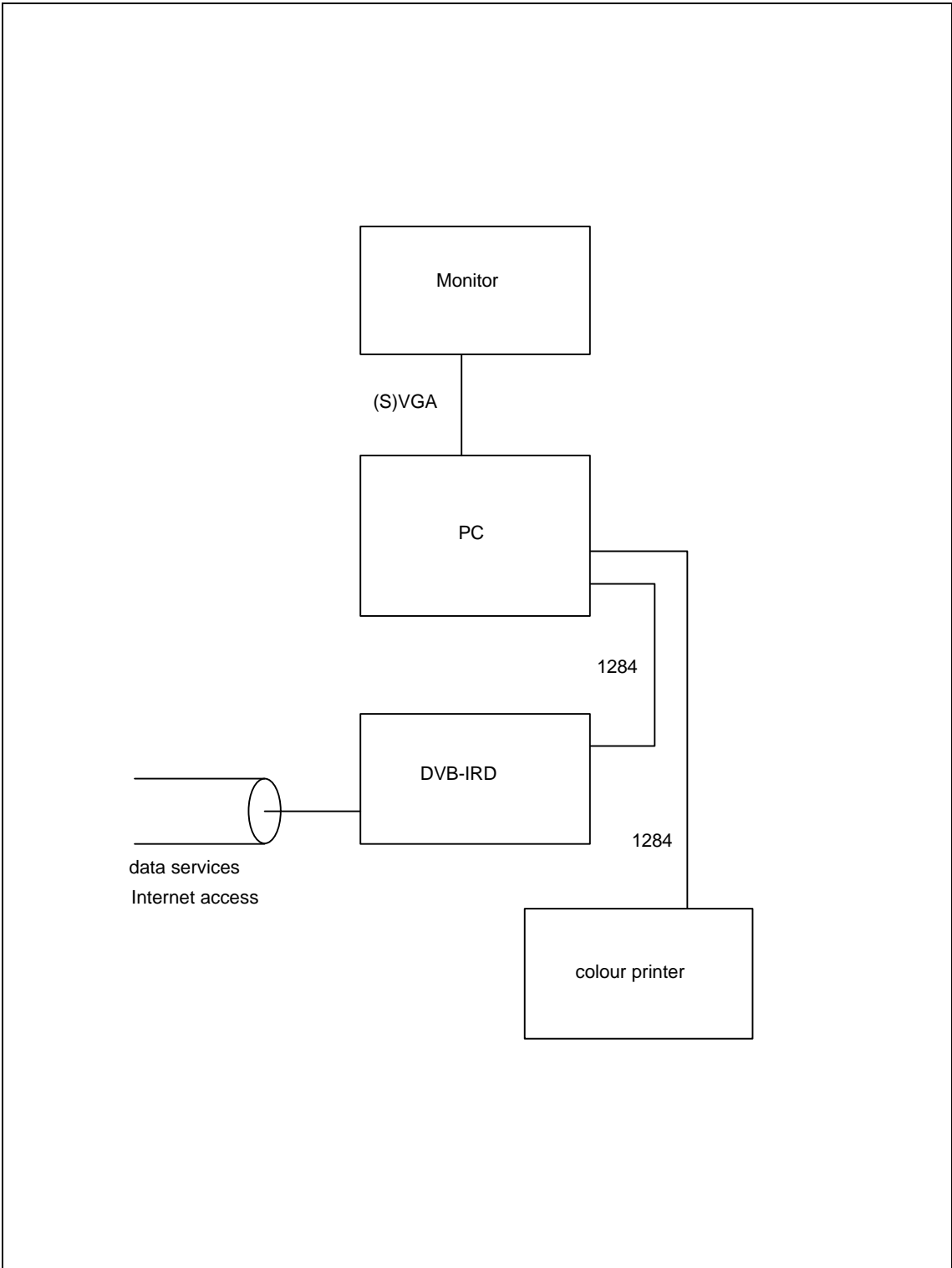

Figure A6: Example of DVB-IRD data services application with high speed parallel interface, employing existing installed base of PC and peripheral equipment

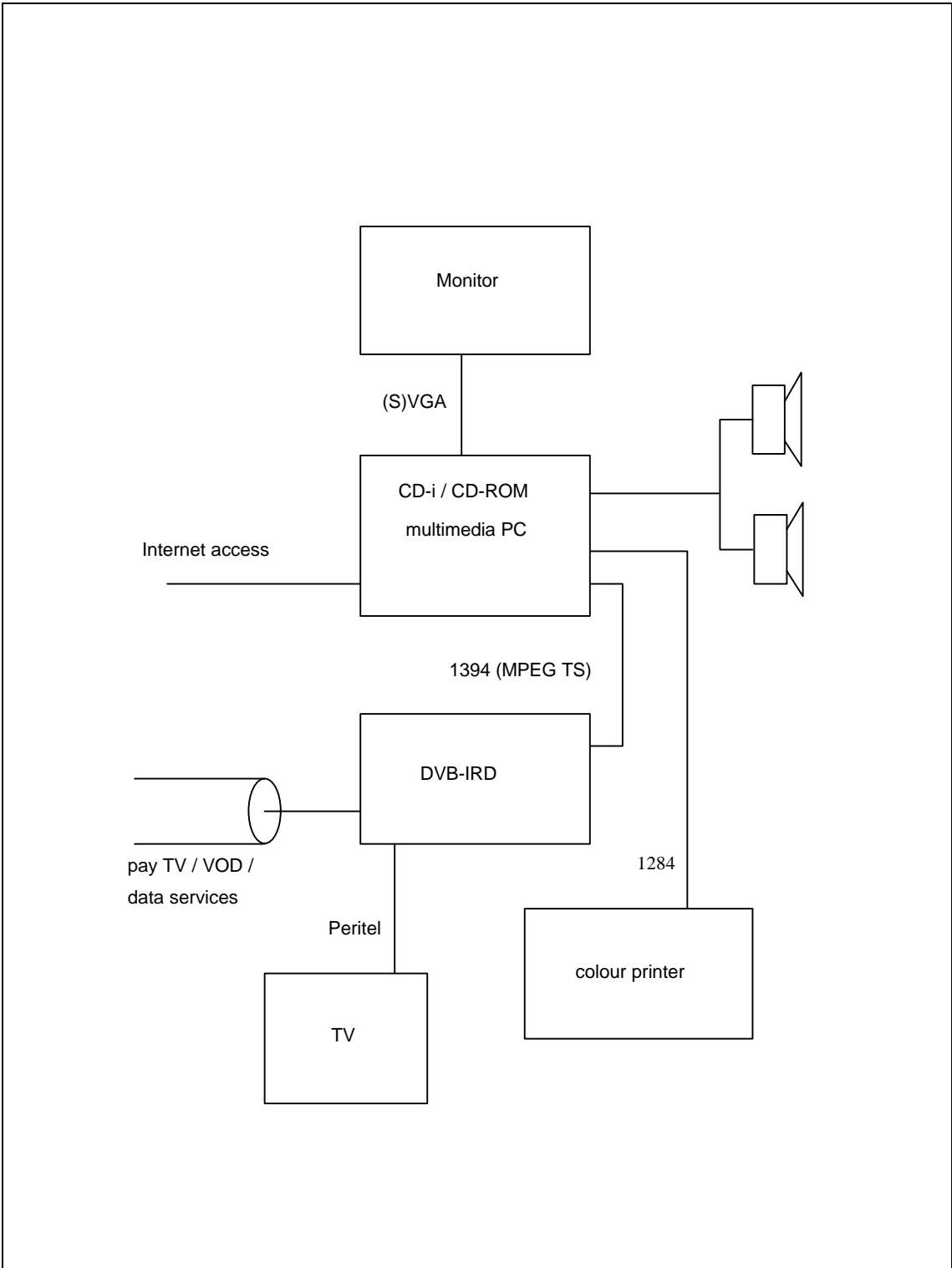

Figure A7: Example of multimedia DVB-IRD application with high speed serial interface

Annex 2 (informative)

The following tables provide a survey of national differences regarding channel assignments on CATV installations (reference "Fernsehstandards nach CCIR und FCC" by Rohde & Schwartz).

Table 2 Standards for European Countries

Country	VHF	UHF	Colour	Country	VHF	UHF	Colour
Austria	B	G	PAL	Italy		B	G PAL
Belgium	B	G	PAL	Luxemburg		B	G PAL
Bulgaria	D	K	SECAM	Malta		B	- PAL
Bosnia	B	G	PAL	Netherlnd		B	G PAL
Cyprus	B	G	SECAM	Norway	B	G	PAL
Denmark		B	G PAL	Poland	D	K	SECAM
Finland	B	G	PAL	Portugal	B	G	PAL
France	L	L	SECAM	Rumania		D	K PAL
Germany		B	G PAL	Russia	D	K	SECAM
Gibraltar		B	G PAL	Slowenia		D	K SECAM
Greece	B	G	SECAM	Slowakia		D	K SECAM
Hungary	D	K	SECAM	Spain		B	G PAL
Ireland	I	I	PAL	Sweden	B	G	PAL
Iceland	B	G	PAL	Swiss		B	G PAL
				UK		-	I PAL

NOTE - In table 2 Malta is the only exception possibly requiring a special modulator with VHF output channels.

Table 3 UHF Channels for standards G, I, K, L (CCIR-Norm, 8MHz)

Band	Channel	Channel Limits MHz	Audio Carrier			I MHz	K,L MHz
			Carrier	G	I		
IV	21	470..478	471,25	476,75	477,25	477,75	
	22	478..486	479,25	484,75	485,25	485,75	
	.	8MHz...	+ 8MHz	+ 8MHz	+ 8MHz	+ 8MHz	
	.	etc.		etc.		etc.	etc.
	37	598..606	599,25	604,75	605,25	605,75	
V	38	606..614	607,25	612,75	613,25	613,75	
	.	8MHz...	+ 8MHz	+ 8MHz	+ 8MHz	+ 8MHz	
	.	etc.		etc.		etc.	etc.
	69	854..862	855,25	860,75	861,25	861,75	
	70	Not used					
	etc.						