

# CRYSTAL UNITS

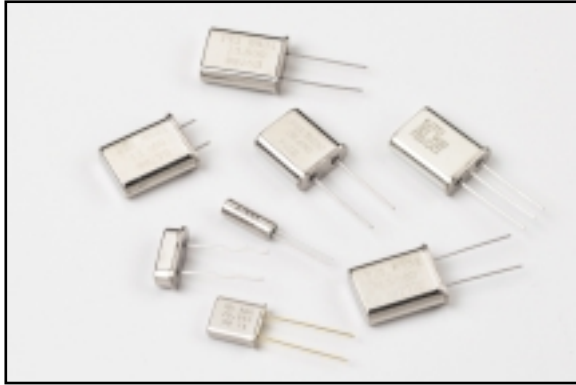

## PRECISION DEVICES INCORPORATED

manufactures a wide variety of crystal products including standard microprocessor units, tight tolerance pager crystals, AT strip, ATS low profile crystals and surface mount packaged crystals. PDI prides itself on its ability to deliver these products using the most competitive manufacturing techniques. For more information see the PDI Crystal Order Form.

## Definitions

### 1. Crystal Equivalent Circuit :

C1 = Motional Capacitance

L1 = Motional Inductance

Rs = Equivalent Series Resistance

Co = Shunt Capacitance

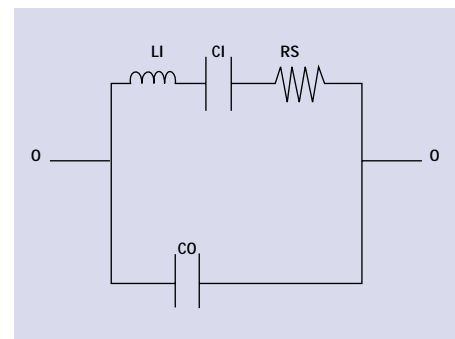

2. **Holder** : Enclosure in which the quartz wafer is mounted.

3. **Nominal Frequency** : Center frequency at which the crystal resonates.

4. **Frequency Tolerance** : The change in frequency allowed from the nominal frequency.

5. **Mode of Oscillation** : The point of oscillation of the nominal frequency.

*(Example: Fundamental Mode, 3rd Overtone, 5th Overtone and 7th Overtone)*

6. **Load Capacitance (CL)** : The capacity specified in pulling the crystal frequency.

*(Crystal will look inductive)*

7. **Motional Capacitance (CI)** : Used in crystal design to determine pullability of crystal.

8. **Equivalent Series Resistance**: Crystal impedance measured in OHMS at series resonance.

9. **Shunt Capacitance (CO)**: The quartz unit measured as a capacitor plus the holder capacitance.

10. **Drive Level**: Power at which the crystal is driven during oscillation.

*(Usually specified in milliwatts)*

11. **Aging**: The frequency change versus time.

12. **Operating Temp Range**: Frequency deviation from Nominal Frequency over a given temperature range.

13. **Spurious Response**: Other frequency responses, other than the main response, usually close in frequency to the main response.

# TYPICAL GATE OSCILLATOR

## OSCILLATOR DESIGN- FUNDAMENTAL

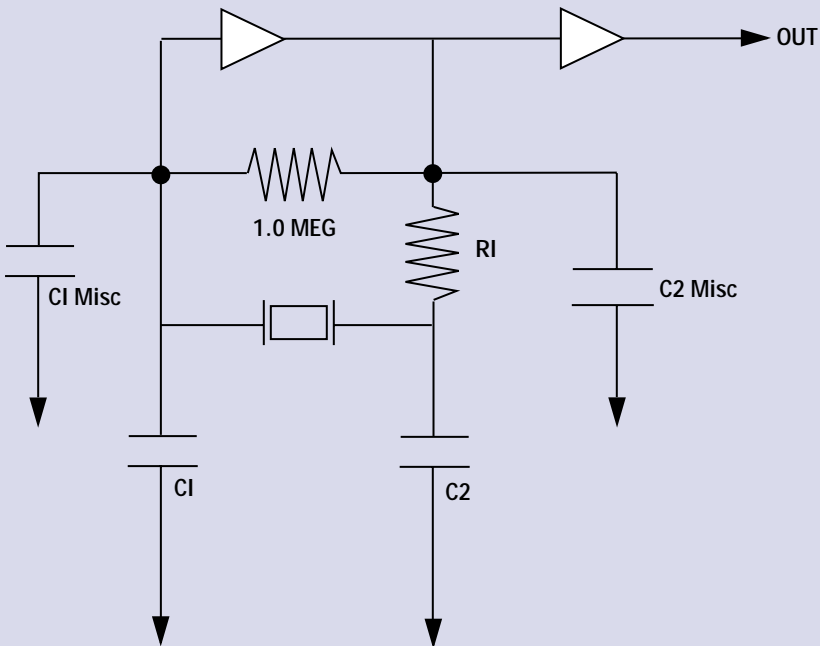

## OSCILLATOR DESIGN- 3RD OVERTONE

